

# Cryo-Torr® High-Vacuum Pump Installation, Operation and Maintenance Instructions

8040613  
Rev. A (4/2001)



**View our inventory**

The information in this document is believed to be accurate and reliable. However, Helix Technology Corporation, cannot accept any financial or other responsibilities that may result from the use of this information. No warranties are granted or extended by this document.

Helix Technology Corporation reserves the right to change any or all information contained herein without prior written notice. Revisions may be issued at the time of such changes and/or deletions.

Any duplication of this manual or any of its parts without expressed written permission from Helix Technology Corporation is strictly prohibited.

Any correspondence regarding this document should be forwarded to:

Helix Technology Corporation  
Mansfield Corporate Center  
Nine Hampshire Street  
Mansfield, Massachusetts 02048-9171 U.S.A.

Telephone: (508) 337-5000  
FAX: (508) 337-5464

The following Helix Technology Corporation trademarks and service marks may appear in this document:

Conductron™	Convectron®	Cryodyne®	Cryogen®
Cryogenerator®	Cryo-Torr®	CTI-Cryogenics®	FastRegen™
GOLDLink <sup>SM</sup>	Granville-Phillips™	GUTS®	Helix Technology.. Your Vacuum Connection <sup>SM</sup>
Helix®	Micro-Ion®	Mini-Ion™	On-Board®
RetroEase®	RetroFast®	Stabil-1®	Stabil-Ion®
ThinLine™	TurboPlus®	Vacuum Assurance <sup>SM</sup>	

All other trademarks or registered trademarks are the property of their respective holders.

## Table of Contents

### Section 1 - Cryo-Torr Cryopump Description

Introduction .....	1-1
Installation, Operation, and Service Instructions .....	1-1
Specifications .....	1-4
Theory of Operation .....	1-12
Cold Head .....	1-12
Vacuum Vessel and Arrays .....	1-12
Compressor Gas and Oil Flows .....	1-14
Cryo-Torr Interface .....	1-14

### Section 2 - Installation

Introduction .....	2-1
Installation .....	2-2
Vent Pipe Connection .....	2-2
Roughing Pump Connection .....	2-3
Helium Return and Supply Line Connections .....	2-5
Power Cable Connection .....	2-5
Crossover Pressure Calculations .....	2-6
Optimizing Crossover Pressure .....	2-7
Cryo-Torr Cryopump Capacity Calculations .....	2-7
Crossover Cycle Calculations .....	2-8
Cryopump Start-up Procedure .....	2-9
Cryopump Shutdown Procedure .....	2-9
Cryopump Storage .....	2-10

### Section 3 - Regeneration

Introduction .....	3-1
When to Regenerate .....	3-1
Assisted Regeneration .....	3-2

### Section 4 - Troubleshooting

Troubleshooting the Cryopump .....	4-1
Technical Inquiries .....	4-1

### Section 5 - Maintenance Procedures

Helium Circuit Decontamination .....	5-1
Cryo-Torr Cryopump Decontamination Procedures .....	5-1
Cleaning the Cryo-Torr Cryopump .....	5-3

## Table of Contents (continued)

### Appendix A - Customer Support Centers

#### Figures

Figure 1-1: Cryo-Torr High-Vacuum Pumps .....	1-2
Figure 1-2: Cryo-Torr High-Vacuum Pumps .....	1-3
Figure 1-3: Cutaway View of a Typical Cryo-Torr High-Vacuum Pump . . .	1-13
Figure 1-4: Cryo-Torr Interface .....	1-14
Figure 1-5: Typical Cryo-Torr System with 9000 Series Compressor .....	1-15
Figure 1-6: Typical Cryo-Torr System with 8200 Compressor .....	1-16
Figure 2-1: Block Diagram for Cryo-Torr System Installation .....	2-1
Figure 2-2: Gas and Electrical Component Location on a Typical Cryo-Torr Cryopump .....	2-4

#### Tables

Table 1-1: Cryo-Torr 4F Cryopump Specifications .....	1-4
Table 1-2: Cryo-Torr 8 Cryopump Specifications .....	1-5
Table 1-3: Cryo-Torr 8F Cryopump Specifications .....	1-6
Table 1-4: Cryo-Torr 10 Cryopump Specifications .....	1-7
Table 1-5: Cryo-Torr 100 Cryopump Specifications .....	1-8
Table 1-6: Cryo-Torr 250F Cryopump Specifications .....	1-9
Table 1-7: Cryo-Torr 400 Cryopump Specifications .....	1-10
Table 1-8: Cryo-Torr 500 Cryopump Specifications .....	1-11
Table 2-1: Crossover Values .....	2-6
Table 2-2: Condensable Gases Capacity (Argon, Nitrogen, Oxygen, etc.) . . .	2-7
Table 3-1: Required Accessories for Assisted Regeneration .....	3-2
Table 4-1: Troubleshooting Procedures .....	4-2
Table 5-1: Indium Gasket Screw Torque Specifications .....	5-4
Table A-1: Customer Support Centers .....	A-2

# Section 1 - Cryo-Torr Cryopump Description

## Introduction

Cryo-Torr High-Vacuum Pumps, shown in Figures 1-1 and 1-2, are one of the two major components that make up the Cryo-Torr High-Vacuum Pumping System. The second component is the Compressor. Instructions for the compressor are contained in each compressor manual.

The Cryo-Torr High-Vacuum Pump provides fast, clean pumping of all gases in the  $10^{-3}$  to  $10^{-9}$  torr range. The cryopump operates on the principle that gases can be condensed and held at extremely low vapor pressures, achieving high speeds and throughputs, as described in Tables 1-1 - 1-8.

Your Cryo-Torr High-Vacuum Pump is a highly-reliable and rugged unit that requires a minimum of servicing. Since the cryopump exposes no moving parts, operating fluids, or backing pumps to the vacuum, the possibility of system or process contamination from the cryopump itself is eliminated.

## Installation, Operation, and Service Instructions

Installation, Operation and Maintenance Instructions for your Cryo-Torr vacuum pump provides easily accessible information. All personnel with installation, operation, and servicing responsibilities should become familiar with the contents of these instructions to ensure safe, reliable cryopump performance.

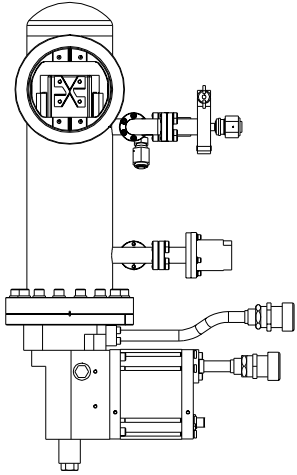

CRYO-TORR 4F

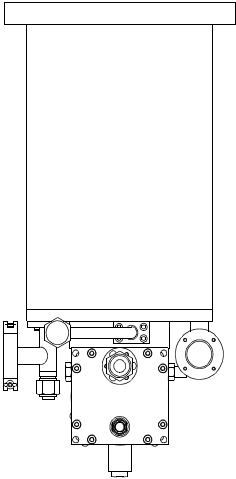

CRYO-TORR 8

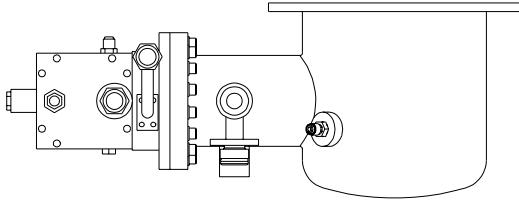

CRYO-TORR 8F

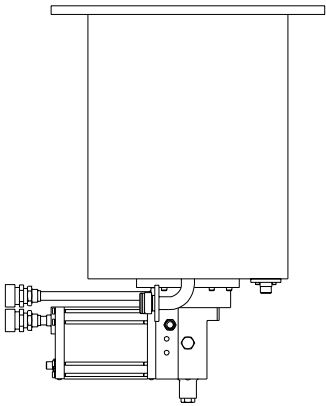

CRYO-TORR 10

**Figure 1-1: Cryo-Torr High-Vacuum Pumps**

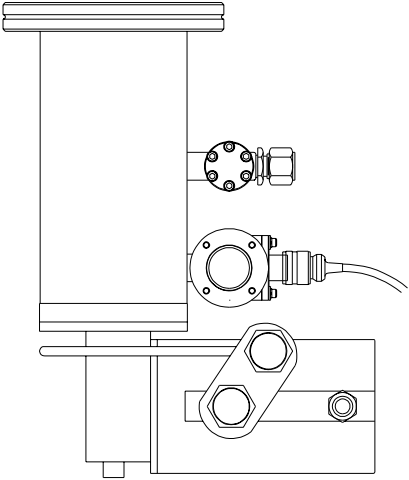

CRYO-TORR 100

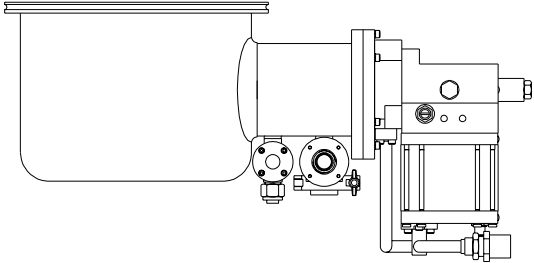

CRYO-TORR 250F

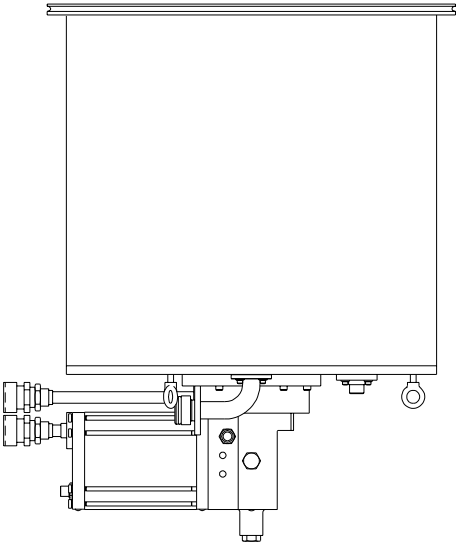

CRYO-TORR 400

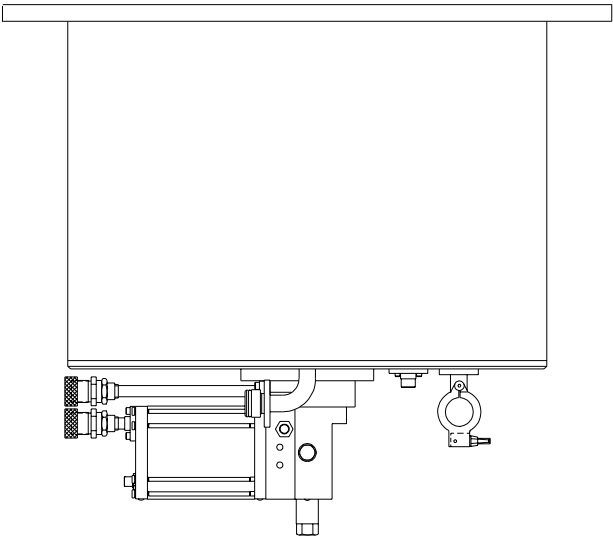

CRYO-TORR 500

**Figure 1-2: Cryo-Torr High-Vacuum Pumps**

## Specifications

**Table 1-1: Cryo-Torr 4F Cropump Specifications**

Parameter	Specifications
Rough Pump Connection	NW 25 ISO KF
Integrated Hardware	Second Stage Diode
Pumping Speeds:	
Water	1100 liters/sec
Air	370 liters/sec
Hydrogen	370 liters/sec
Argon	310 liters/sec
Argon Throughput	300 scc/min. (4 torr liters/second)
Capacity:	
Argon	100 std. liters
Hydrogen	3 std. liters @ $5 \times 10^{-6}$ torr
Crossover	100 torr-liters
Cooldown Time	75 minutes nominal
Dimensions	Length - 21.9 inches (556 mm)
Weight	46 lbs. (101.2 kg)



**Table 1-2: Cryo-Torr 8 Cryopump Specifications**

Parameter	Specifications
Rough Pump Connection	NW 25 ISO KF
Integrated Hardware	Second Stage Diode
Pumping Speeds:	
Water	4000 liters/sec
Air	1500 liters/sec
Hydrogen	2500 liters/sec
Argon	1200 liters/sec
Argon Throughput	700 scc/min. (8.9 torr liters/second)
Capacity:	
Argon	1000 std. liters
Hydrogen	12 std. liters @ $5 \times 10^{-6}$ torr
Crossover	150 torr-liters
Cooldown Time	1.5 hours nominal
Dimensions	Length - 20.7 inches (525.8mm)
Weight	45 lbs. (20.4 kg)

**Table 1-3: Cryo-Torr 8F Cryopump Specifications**

Parameter	Specifications
Rough Pump Connection	NW 25 ISO KF
Integrated Hardware	Second Stage Diode
Pumping Speeds:	
Water	4000 liters/sec
Air	1500 liters/sec
Hydrogen	2200 liters/sec
Argon	1200 liters/sec
Argon Throughput	700 scc/min. (8.9 torr liters/second)
Capacity:	
Argon	1000 std. liters
Hydrogen	8 std. liters @ $5 \times 10^{-6}$ torr
Crossover	150 torr-liters
Cooldown Time	1.5 hours nominal
Dimensions	Length - 22.6 inches (574 mm)
Weight	42 lbs. (19 kg)

**Table 1-4: Cryo-Torr 10 Cryopump Specifications**

Parameter	Specifications
Rough Pump Connection	NW 25 ISO KF
Integrated Hardware	Second Stage Diode
Pumping Speeds:	
Water	9000 liters/sec
Air	3000 liters/sec
Hydrogen	5000 liters/sec
Argon	2500 liters/sec
Argon Throughput	1500 scc/min. (19 torr liters/second)
Capacity:	
Argon	2000 std. liters
Hydrogen	24 std. liters @ $5 \times 10^{-6}$ torr
Crossover	300 torr-liters
Cooldown Time	45 minutes nominal
Dimensions	Length - 23.9 inches (607.1 mm)
Weight	85 lbs. (39 kg)

**Table 1-5: Cryo-Torr 100 Cryopump Specifications**

Parameter	Specifications
Rough Pump Connection	NW 25 ISO KF
Integrated Hardware	Second Stage Diode
Pumping Speeds:	
Water	1100 liters/sec
Air	350 liters/sec
Hydrogen	480 liters/sec
Argon	285 liters/sec
Argon Throughput	75 scc/min. (1 torr liter/second)
Capacity:	
Argon	90 std. liters
Hydrogen	2 std. liters @ $5 \times 10^{-6}$ torr
Crossover	40 torr-liters
Cooldown Time	75 minutes nominal
Dimensions	Length - 12.9 inches (328 mm)
Weight	22 lbs. (10 kg)

**Table 1-6: Cryo-Torr 250F Cryopump Specifications**

Parameter	Specifications
Rough Pump Connection	NW 25 ISO KF
Integrated Hardware	Second Stage Diode
Pumping Speeds:	
Water	9500 liters/sec
Air	4000 liters/sec
Hydrogen	6800 liters/sec
Argon	3300 liters/sec
Argon Throughput	1500 scc/min.
Capacity:	
Argon	2000 std.
Hydrogen	18 std. liters @ $5 \times 10^{-6}$ torr
Crossover	300 torr-liters
Cooldown Time	1 hour, 40 minutes nominal
Dimensions	Length - 12.21 in. Maximum Width from Center Line - 22.49 in.
Weight	90 lbs.

**Table 1-7: Cryo-Torr 400 Cryopump Specifications**

Parameter	Specifications
Rough Pump Connection	NW 25 ISO KF
Integrated Hardware	Second Stage Diode
Pumping Speeds:	
Water	16,000 liters/sec
Air	6000 liters/sec
Hydrogen	12,000 liters/sec
Argon	5000 liters/sec
Argon Throughput	500 scc/min. (6.3 torr liters/second)
Capacity:	
Argon	2500 std.
Hydrogen	30 std. liters @ $5 \times 10^{-6}$ torr
Crossover	300 torr-liters
Cooldown Time	2.5 hours nominal
Dimensions	Length - 24.00 inches (328 mm)
Weight	160 lbs. (72.5 kg)

**Table 1-8: Cryo-Torr 500 Cryopump Specifications**

Parameter	Specifications
Rough Pump Connection	NW 25 ISO KF
Integrated Hardware	Second Stage Diode
Pumping Speeds:	
Water	30,000 liters/sec
Air	10,000 liters/sec
Hydrogen	10,000 liters/sec
Argon	8400 liters/sec
Argon Throughput	500 scc/min. (6.3 torr liters/second)
Capacity:	
Argon	3000 std. liters; 1,500,000 torr-liters
Hydrogen	16 std. liters @ $5 \times 10^{-6}$ torr
Crossover	500 torr-liters
Cooldown Time	3 hours nominal
Dimensions	Length - 23.84 inches (605.54 mm)
Weight	205 lbs. (93.0 kg)

## Theory of Operation

Your Cryo-Torr Cryopump consists of a cold head and a vacuum vessel. An 80K condensing array, a 15K array, cold head station heaters, and an 80K radiation shield are located in the vacuum vessel. The cold station heaters and 15K array are secured to the cold head, which is welded to the vacuum vessel. The cold head provides cooling to the three arrays. Gases are removed from your vacuum chamber, thereby creating a vacuum when they are condensed or adsorbed on the cryogenically-cooled arrays.

### Cold Head

The cold head consists of a two-stage cold head cylinder (part of the vacuum vessel) and drive unit displacer assembly, that together produce closed-cycle refrigeration at temperatures that range from 60 to 120K for the first-stage cold station to 10 to 20K for the second-stage cold station, depending on operating conditions. Within the drive unit displacer assembly, the drive unit actuates the displacer-regenerator assembly located in the cold head cylinder and thereby controls the flow of helium into the cold head. Within the drive unit are located the crankcase and drive motor, which is a direct-drive constant-speed motor, operating at 72 rpm on 60Hz power and 60 rpm on 50 Hz power.

During operation, high pressure helium from the compressor enters the cold head at the helium supply connector, and flows through the displacer-regenerator assembly, crankcase, and motor housing before exiting through the helium gas return connector and returning to the compressor. Helium expansion in the displacer-regenerator assembly provides cooling at the first and second stage cold stations.

### Vacuum Vessel and Arrays

The 80K condensing array, as shown in Figure 1-3, condenses water and hydrocarbon vapors. The 15K array condenses nitrogen, oxygen, and argon while the specially processed charcoal of this array traps helium, hydrogen, and neon.



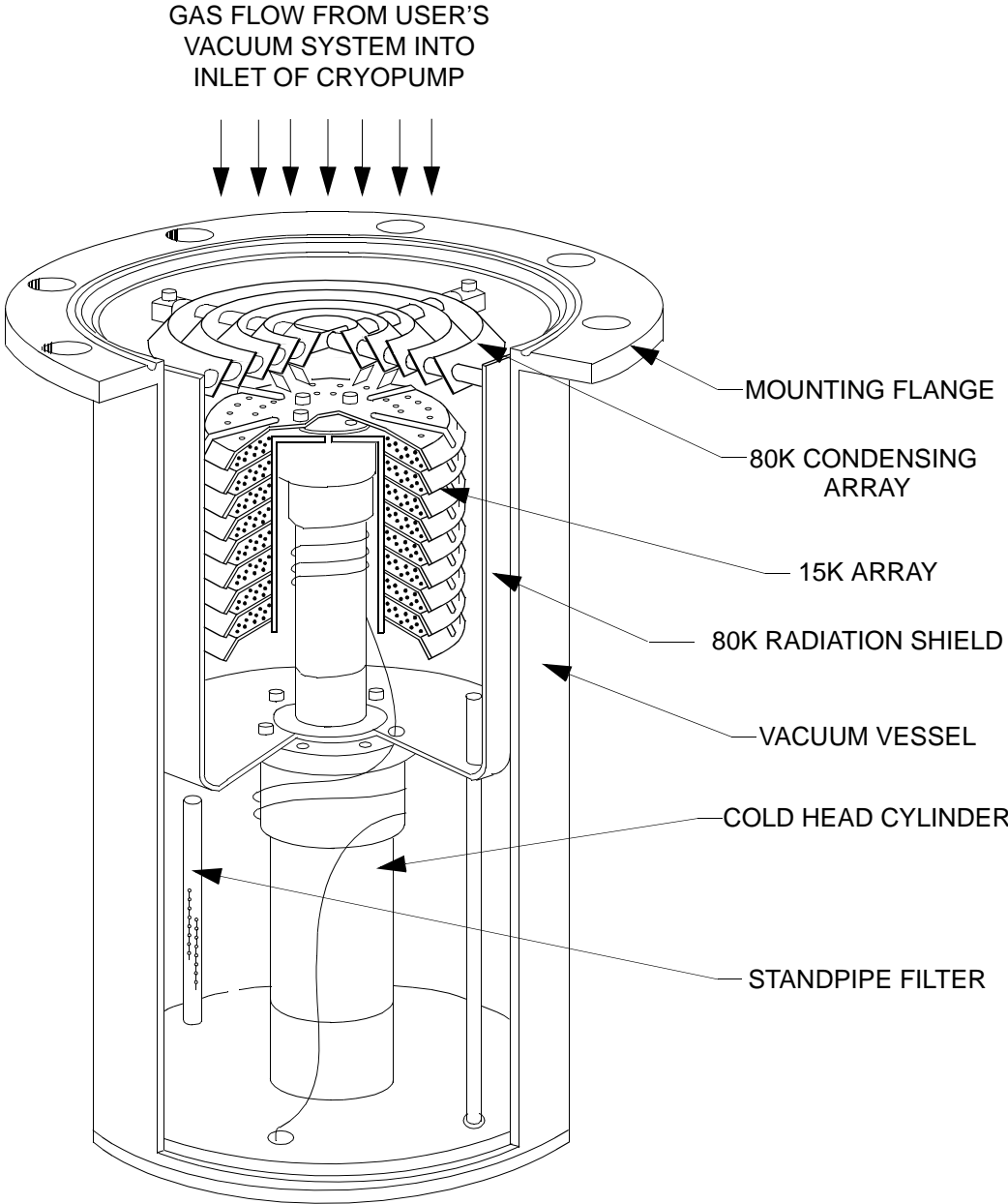

**Figure 1-3: Cutaway View of a Typical Cryo-Torr High-Vacuum Pump**

## Compressor Gas and Oil Flows

Helium returning from the cryopump cold head enters the compressor, and a small quantity of oil is injected into the gas stream, thereby overcoming helium's low specific heat and inability to carry heat produced during compression. Helium is then compressed and passed through a heat exchanger for removal of compression-caused heat.

The helium continues its flow through an oil-mist separator and a charcoal filter adsorber (cartridge), within the compressor, where oil and contaminants are removed. A differential pressure relief valve in the compressor limits the operating pressure differential between the helium supply and return lines, thereby allowing compressor operation without cold head operation. When cold head operation reaches a steady-stage condition, further pressure regulation is unnecessary.

## Cryo-Torr Interface

The Cryo-Torr Interface, shown in Figure 1-3, is required when; connecting more than one Cryo-Torr Cryopump to a variety of CTI-CRYOGENICS Compressors, or when connecting a single Cryo-Torr Cryopump to the 9000 Series of compressors.

The Cryo-Torr Interface accepts input cryopump power from the compressor and distributes it to a maximum of three Cryo-Torr Cryopumps. The Cryo-Torr Interface also supports a Compressor Remote feature which can be used to turn the Cryo-Torr Cryopumps off when the compressor is turned off.

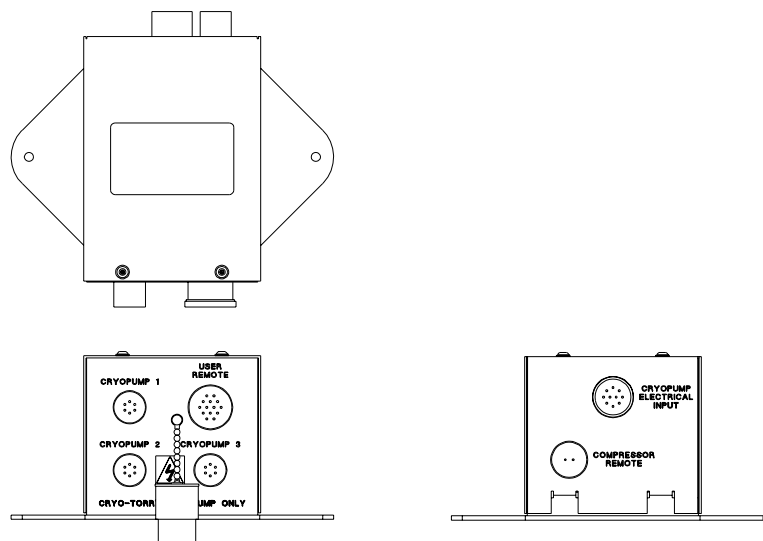

**Figure 1-4: Cryo-Torr Interface**

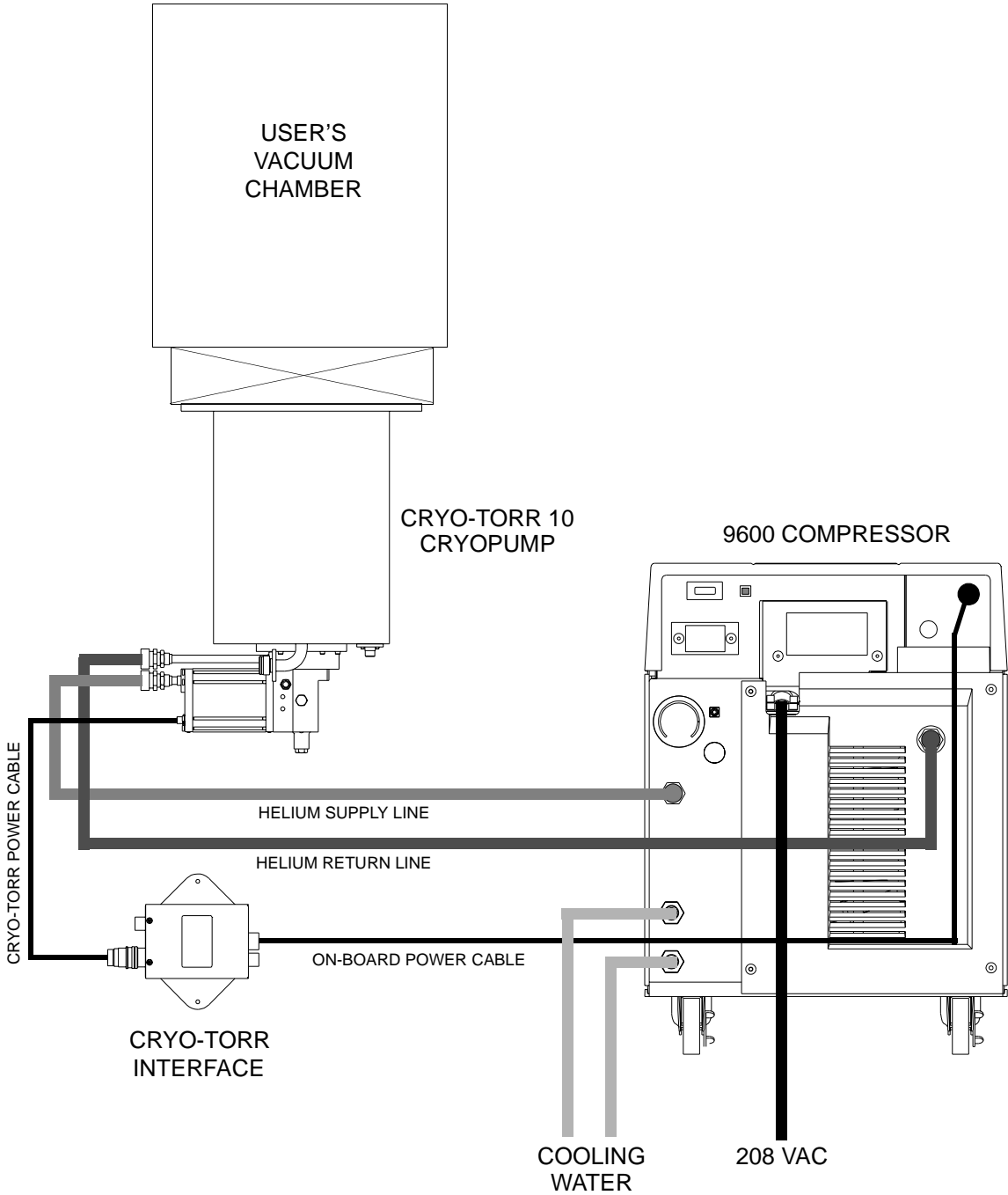

**Figure 1-5: Typical Cryo-Torr System with 9000 Series Compressor**

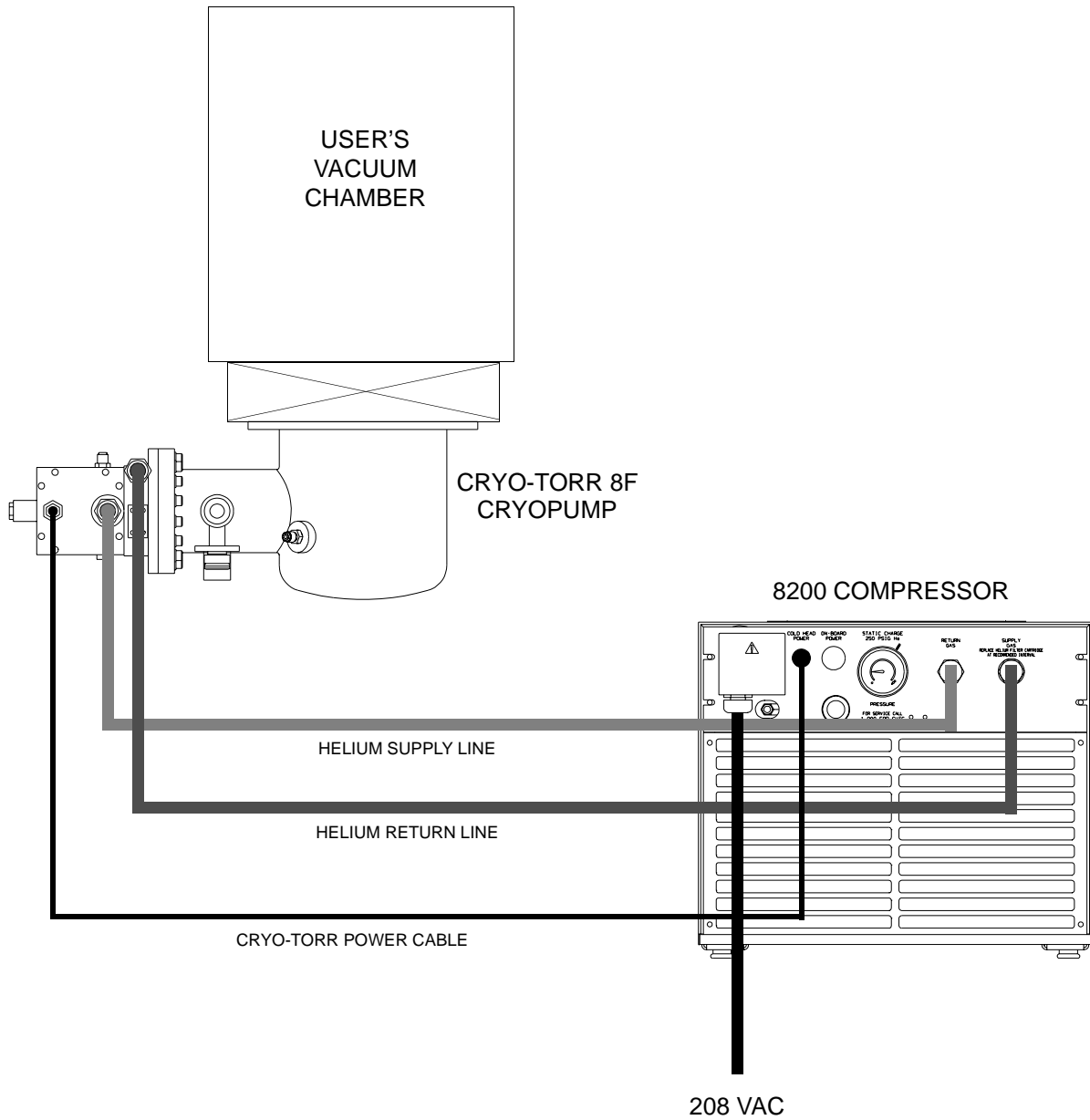
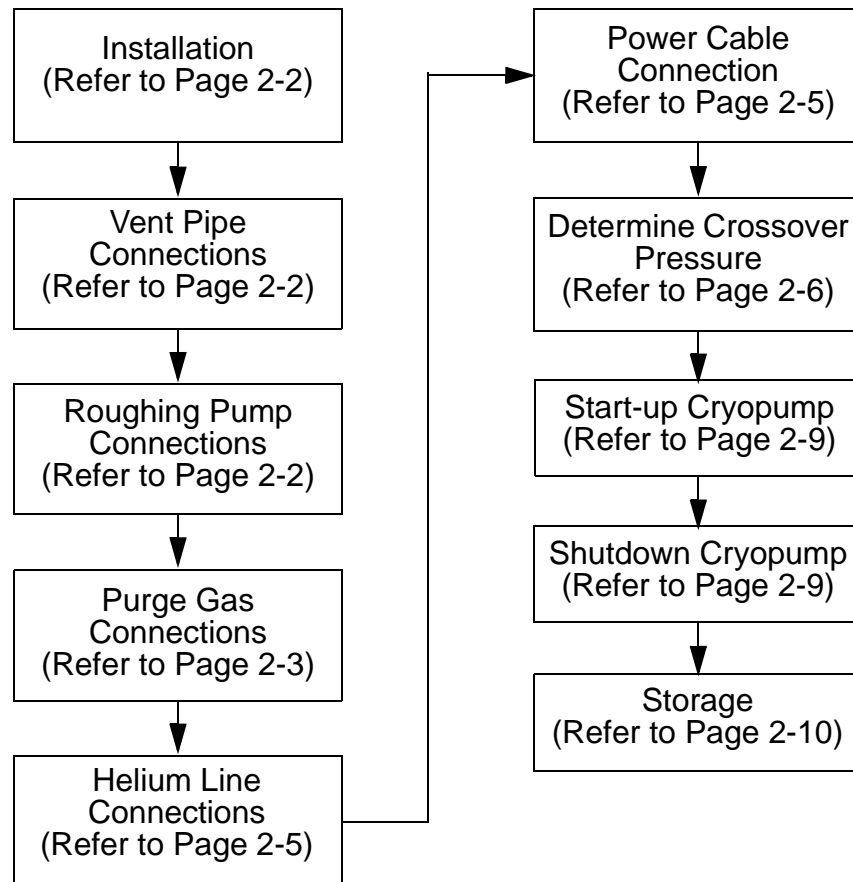

**Figure 1-6: Typical Cryo-Torr System with 8200 Compressor**

## Section 2 - Installation

### Introduction

Installation information is presented for experienced and non-experienced Cryo-Torr Cryopump system technicians. The flowchart in Figure 2-1 highlights the major tasks for installation of Cryo-Torr Cryopumps. Refer to Figure 2-1 and the appropriate installation procedure within this section for the type of cryopump being installed.



**Figure 2-1: Block Diagram for Cryo-Torr System Installation**

## Installation

The cryopump may be installed in any orientation without affecting its performance.

Before mounting the cryopump to the vacuum system, a high-vacuum isolation valve (Hi-Vac valve) should be installed between the cryopump and vacuum chamber to isolate the cryopump from the chamber during rough pumping, cooldown, and regeneration.

Install the cryopump to the vacuum system as follows:

1. Remove the protective cover from the main flange of the cryopump.
2. Clean all sealing surfaces and install the O-ring or metal seal gasket as appropriate.
3. Mount the cryopump to the Hi-Vac valve or vacuum chamber mounting flange. Be sure all mounting bolts are secure.

### Vent Pipe Connection

The cryopump pressure relief valve can be vented directly into the room or can be connected to an exhaust system.

	<b>WARNING</b>
If toxic, corrosive, or flammable gases are pumped, a vent pipe must be connected to the cryopump relief valve and directed to a safe location.	

When connecting a vent pipe to your cryopump, the 1.30-inch diameter x 1.38-inch long volume around the relief valve must remain open for proper relief valve operation.

Vent pipe adapters are available from CTI-CRYOGENICS (P/N 8080250K008).

## **Roughing Pump Connection**

Connect your Cryo-Torr Cryopump to a roughing pump system using a roughing line with the largest inside diameter possible to minimize the roughing time required during start-up procedures prior to normal operation. The roughing pump should have a blank-off pressure of less than 20 microns. The roughing pump connects to the Cryo-Torr Cryopump roughing valve. The valve will accept an ISO NW-25 flange.

A molecular sieve roughing trap to minimize oil backstreaming from your roughing pump system is recommended and should be installed in the roughing pump line near the roughing pump. The trap must be properly maintained. Connect the roughing valve to the roughing pump as follows:

1. Install the roughing pump line to the cryopump roughing valve port using the clamp provided. Tighten the clamp securely.

## **Purge Gas Connection**

Connect your purge gas supply line to the purge valve 1/8 NPTF fitting. Adjust the supply pressure to achieve 1-2 cfm.

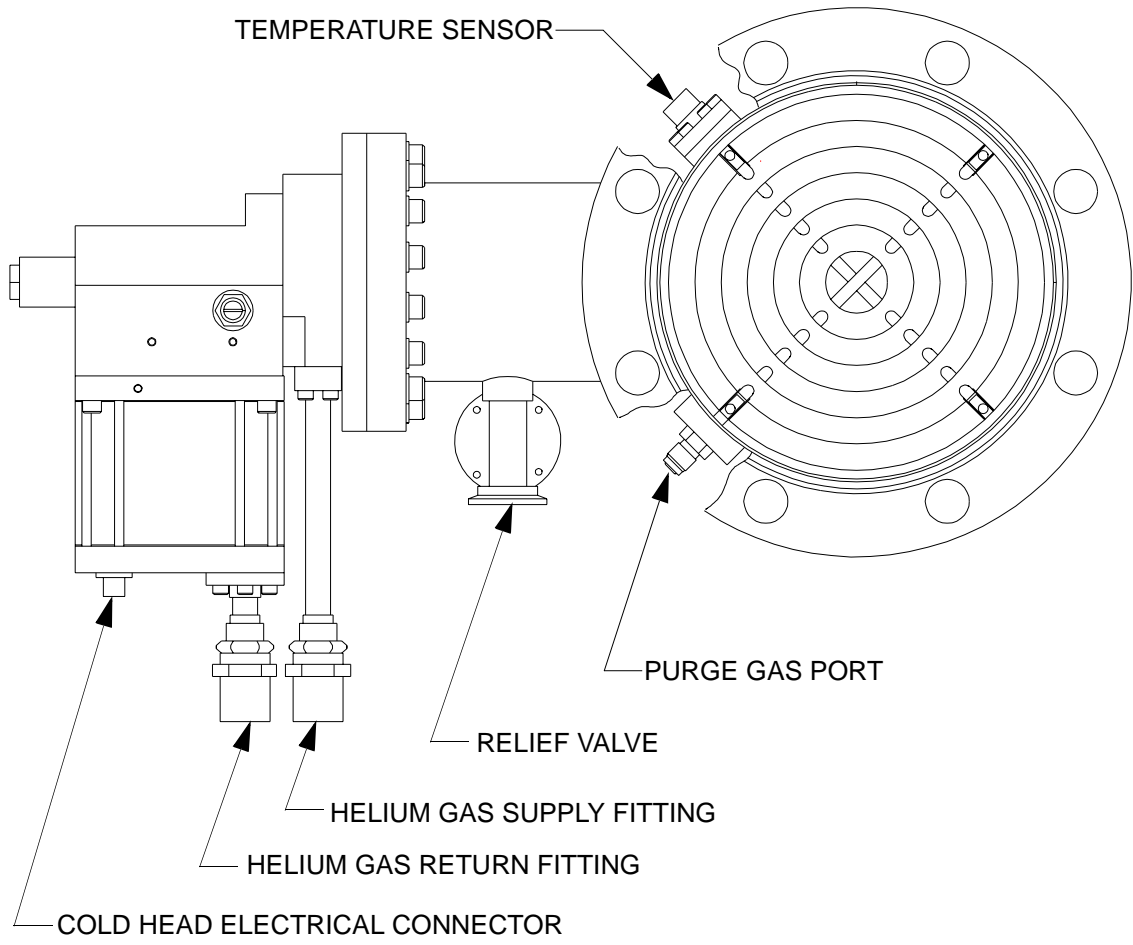

**Figure 2-2: Gas and Electrical Component Location on a Typical Cryo-Torr Cryopump**



## Helium Return and Supply Line Connections

Make the connections between the cryopump and compressor. Refer to Figure 2-2, while making the component interconnections.

1. Remove all dust plugs and caps from the supply and return lines, compressor, and cryopump. Check all fittings.
2. Connect the helium-return line from the gas-return connector on the rear of the compressor to the gas-return connector on the Cryo-Torr Cryopump.
3. Connect the helium supply line from the supply connector on the cartridge to the gas-supply connector on the Cryo-Torr Cryopump.
4. Attach the supply and return line identification decals (CTI-CRYOGENICS supplied) to their respective connecting piping ends.

**NOTE:** Verify proper helium supply static pressure as described in the Installation Section of the appropriate Compressor Manual.

## Power Cable Connection

### CAUTION

The system power circuit breaker switch at the back of the compressor must be in the OFF position before making any and all electrical connections.

Do not connect the compressor to its power source until all connections have been made between the components of the Cryo-Torr system.

1. Connect the Cryo-Torr power cable from the cold head connector on the compressor to the Cryo-Torr Cryopump power connector.

## Crossover Pressure Calculations

Crossover is that point in time when the pumping of a vacuum chamber is switched from *rough* pumping to *high-vacuum* pumping. Rough pumping brings the vacuum chamber pressure from one atmosphere (760 torr) down to a pressure of approximately 0.5 torr. At crossover, the roughing valve is closed and the high vacuum valve is opened bringing the vacuum chamber down to a pressure typically less than  $10^{-6}$  torr. This momentary pulse of gas and water molecules is cryo-condensed on the arrays of the Cryo-Torr Cryopump.

To determine the maximum permissible crossover pressure (CP), perform the following calculation using the crossover values (CV) for your model Cryo-Torr Cryopump shown in Table 2-1 and the actual volume of your vacuum chamber (VC).

**Table 2-1: Crossover Values**

Cryo-Torr Pump	Torr-Liters
4	100
8	150
8F	150
10	300
100	40
250F	300
400	300
500	500

Where VC = 100 liters:

$$CP = \frac{\text{CROSSOVER VALUE}}{\text{VACUUM CHAMBER VOLUME}} = \frac{CV}{VC}$$

$$CP = \frac{300 \text{ TORR-LITERS}}{100 \text{ LITERS}} = 3 \text{ TORR}$$

### Optimizing Crossover Pressure

The calculated crossover pressure may not be optimized for your system. To help prevent any backstreaming during the roughing of the vacuum chamber, you should stop roughing at as high a pressure as possible. The optimum crossover pressure for a vacuum chamber should cause a very slight rise in temperature with a rapid recovery. Increase the roughing pressure in small increments (15-20%) until the rise in temperature is noted; then drop the value by a small amount (10%). This will be the optimum pressure for that vacuum chamber.

### Cryo-Torr Cryopump Capacity Calculations

Cryopump capacity is defined as the total standard liters of gas that can be accommodated within a cryopump prior to regeneration. The number of hours between regeneration cycles can be easily calculated in the case of a continuous gas flow of a known gas species:

$$A = \frac{16.6 \times C}{B}$$

Where:

A = Duration of operation with a continuous gas flow (hours)

B = Gas flow (scc/min.)

C = Cryo-Torr capacity for the particular gas species being flowed (std. liters) as shown in Table 2-2.

**Table 2-2: Condensable Gases Capacity (Argon, Nitrogen, Oxygen, etc.)**

Parameter	Value
Cryopump	Cryo-Torr 10F
Standard Liters	2000
Torr-Liters	1,500,000

Example:

For a sputtering application of continuously flowing argon gas at 70 scc/min, the duration of continuous operation with this gas flow (between regeneration) would be:

$$A = \frac{16.6 \times 2000 \text{ (std liters)}}{70 \text{ (scc/min)}} = 474 \text{ hours}$$

### Crossover Cycle Calculations

The number of crossover cycles between regeneration cycles can also be easily calculated when the crossover pressure and vacuum chamber volume are known:

$$N = \frac{760,000 \text{ torr-liters}}{P \times V}$$

Where:

N = Number of crossover cycles

V = Volume of vacuum chamber (liters)

P = Pressure of vacuum chamber prior to crossover (torr)  
(roughing pressure)

Example:

For a vacuum chamber of 100 liters and a roughing pressure of 1.5 torr, the number of crossover cycles between regeneration cycles would be:

$$N = \frac{760,000 \text{ torr-liters}}{1.5 \text{ (torr)} \times 100 \text{ (liters)}} = 5,060 \text{ cycles}$$

## Cryopump Start-up Procedure

1. Close the Hi-Vac valve to isolate the Cryo-Torr Cryopump.
2. Initiate a Nitrogen purge of the Cryo-Torr Cryopump for one hour.
3. Open the roughing valve and rough the Cryo-Torr Cryopump to 50 microns. Close the roughing valve.

**NOTE:** If step 4 cannot be achieved, repeat step 3.

4. Check the rate-of-rise. The rate-of-rise should be 10 microns/minute.

**NOTE:** Cryo-Torr Cryopump power is turned ON/OFF when compressor power is turned ON/OFF.

5. Turn compressor power ON.
6. Wait for the second stage temperature (T2) to be less than 17 K.
7. Open the Hi-Vac valve.

## Cryopump Shutdown Procedure

Typically, a cryopump can be left in operation continuously if you are not processing or not using the vacuum chamber, by simply closing the Hi-Vac valve to isolate the cryopump from your vacuum chamber. You are now able to load, unload, repair or replace components in the chamber and the cryopump will be available for restarting the process as necessary.

1. Close the Hi-Vac valve to isolate the cryopump.
2. Shut off the cryopump by removing the input power cable to the cryopump motor.
3. Initiate Nitrogen gas purge.
4. Continue Nitrogen gas purge until ambient temperature is reached.
5. Shut off the Nitrogen gas purge.

## Cryopump Storage



### WARNING

If the cryopump has been used to pump toxic or dangerous materials, you must take adequate precautions to safeguard personnel. If such a cryopump is shipped to a Product Service Department, clearly mark on all storage cartons the identity of the toxic or dangerous materials to which the cryopump has been subjected. All shipped equipment that contains hazardous/toxic materials must conform to DOT regulations.

If the cryopump is stored while attached to your vacuum system, the cryopump vacuum vessel should be kept at a slight positive atmospheric pressure with dry nitrogen or argon.

If the cryopump is removed from your vacuum system, install the protective cover on the mounting flange of the cryopump vacuum vessel inlet before storage.

The remaining components of your Cyro-Torr high vacuum pump system are fully protected during storage if kept under positive helium pressure and all component connections left connected. Periodically, check the helium supply pressure gauge on the compressor and refer to the compressor manual for the proper static charge pressure.

## Section 3 - Regeneration

### Introduction

A Cryo-Torr cryopump periodically requires a regeneration cycle to return it to its original operating capabilities.

Gases captured from a vacuum chamber and trapped in the cryopump through condensation and cryo-adsorption are held primarily in an ice-like form. A regeneration cycle removes trapped gases through a process similar to defrosting a refrigerator freezer compartment.

During a regeneration cycle, the cryopump is warmed to room temperature or higher, allowing trapped gases to change from a solid state to a gaseous state and thereby released from the cryopump through the pressure relief valve to the atmosphere.

	<p style="text-align: center;"><b>WARNING</b></p> <p>If toxic, corrosive, or flammable gases are pumped, a vent pipe must be connected to the cryopump relief valve and directed to a safe location.</p>
--	--

### When to Regenerate

The need to regenerate the Cryo-Torr high-vacuum pump as a result of saturation is a function of the cryopump capacity and the process gas throughput.

If the cryopump becomes incapable of maintaining a high-vacuum (typically an increase in your vacuum chamber base pressure by a factor of 10, even though the cold head and compressor unit are operating satisfactorily), the cryopump requires regeneration.

It is recommended that your cryopump be regenerated on a regular schedule coinciding with system maintenance, weekend system shutdown, etc. A suitable time interval between regeneration cycles can be determined from experience.

Extended loss of electrical power (10 minutes or longer), system vacuum failure, such as venting with a partially open vacuum isolation valve, and operator error may necessitate cryopump regeneration.

**NOTE:** Short term electrical outages of up to 10 minutes should not result in the need to regenerate your cryopump.

## Assisted Regeneration

A regeneration cycle incorporating the use of a heated dry inert purge gas (nitrogen/argon) is the preferred method of regeneration and will overcome unassisted regeneration technical difficulties by:

- Minimizing the required time to bring the condensing and cryo-adsorbing arrays to room temperature
- Reducing the time required to rough the cryopump because the dry inert purge gas will minimize the amount of residual water vapor in the 15K array
- Diluting hazardous gases and ensuring their removal from the cryopump housing

**Table 3-1: Required Accessories for Assisted Regeneration**

Part Number	Description
8080250K020	Purge Gas Heater, 110 V
8080250K023	Purge Gas Solenoid Valve, 110V

**NOTE:** Call 1-800-FOR GUTS to obtain the accessories listed in Table 3-1.

1. Close the Hi-Vac isolation valve.
2. Shut off the cryopump by setting the System Power switch on the compressor to the OFF position.
3. Immediately introduce heated dry purge gas through the vacuum vessel purge fitting at approximately 150° F (66° C) and at a flow rate of 1 -2 cfm. Allow the purge gas to vent through the relief valve.
4. Halt the gas purge when the condensing arrays reach 80° F (26° C) (300K).



5. When the condensing arrays reach ambient temperature, rough the cryopump to an initial starting pressure, usually between 50 and 100 microns.

***NOTE:** After roughing, perform a rate-of-rise (ROR) test to ensure that your cryopump regeneration has been thorough and that no air-to-vacuum leaks are present.*

6. Perform the rate-of-rise test as follows:
  - a. Once the roughing cycle has roughed the cryopump starting pressure to between 50 - 100 microns, close the roughing valve.
  - b. Observe the rate of pressure rise (ROR) over a five minute period.

***NOTE:** The ROR should be less than 10 microns/minute over a five minute period (50 microns total).*

- c. If the ROR is greater than 50 microns, repurge the cryopump, check for leaks, and repeat steps 5 and 6.
7. Close the cryopump roughing valve and start the cryopump.
8. The cryopump is ready for use when the second stage array reaches a temperature of 20K or lower.

## Section 4 - Troubleshooting

### Troubleshooting the Cryopump

The primary indication of trouble in a vacuum pumping system is a rise in base pressure in your vacuum chamber. A rise in the base pressure may be caused by a leak in the vacuum system or by a fault in the cryopump or saturation of the 15K cryo-adsorbing charcoal array (regeneration may be necessary). If the cryopump temperature is below 20K it must pump at rated capacity; a high base pressure is usually caused by an air-to-vacuum leak in the system.

If you suspect a leak in your vacuum system, isolate the cryopump by closing the Hi-Vac valve and leak check your vacuum chamber. If no leaks are found, a leak may be present below the Hi-Vac valve (cryopump). Leak checking below the Hi-Vac valve should be performed with the cryopump shut OFF and at room temperature. Leak checking while the cryopump is operating may mask leaks that are present (due to the ability of the cryopump to pump helium). If no leak is found, refer to the cryopump troubleshooting procedures summarized in Table 4-1.

The problems presented in Table 4-1 are followed by possible causes and corrective actions. The causes and corresponding actions are listed in their order of probability of occurrence.

Maintaining a log of certain parameters during normal operation can be a valuable tool in troubleshooting the cryopump. The log may contain many parameters, however, the following minimum parameters should be included: the cooldown time to 20K, the roughing time to 50 $\mu$ , the time to base pressure at crossover, the time between regeneration cycles, and the compressor pressure reading.

### Technical Inquiries

Please refer to **Appendix A** of this manual for a complete list of the CTI-CRYOGENICS' world wide customer support centers.

**Table 4-1: Troubleshooting Procedures**

Problem	Possible Cause	Corrective Action
High base pressure of vacuum system, and a cryopump temperature <i>below</i> 20K.	Air-to-vacuum leak in vacuum system or in cryopump.	Check cryopump relief valve for proper seating.  Check cryopump for leaks.  Check vacuum chamber and Hi-Vac valve for leaks.
	High partial pressure of non-condensables (helium, hydrogen, or neon) within the cryopump because the 15K array has reached full capacity.	Regenerate the cryopump as described in <b>Section 3 - Regeneration</b> .
	One of the arrays is loose, which is preventing good thermal contact with the cold station.	Warm the cryopump to ambient temperature and retighten the array mounting screws to 15 - 20 in. lbs.
High base pressure of vacuum system, and a cryopump temperature <i>above</i> 20K.	Decrease in cryopump cold head performance.	If the helium return pressure gauge reads below the normal-operating return pressure 60-85 psig (415-590 kPa), add gas as described in the appropriate Compressor manual.
	High partial pressure of non-condensables (helium, hydrogen, or neon) within the cryopump because the 15K array has reached full capacity.	Regenerate the cryopump as described in <b>Section 3 - Regeneration</b> .
	Excessive thermal load on frontal array.	Reduce the thermal radiation load by 1) shielding the cryopump or 2) lowering the temperature of the radiating surface.

**Table 4-1: Troubleshooting Procedures (Continued)**

Problem	Possible Cause	Corrective Action
Cryopump fails to cool down to the required operating temperature or takes too long to reach that temperature (20K).	Low helium supply pressure.	Add gas as described in the appropriate Compressor manual.
	Compressor problems.	Refer to Troubleshooting section of the appropriate Compressor manual.
	Vacuum leak in vacuum system or cryopump.	Check the cryopump relief valve for proper seating.  Check cryopump for leaks.  Check vacuum system for leaks.
	Incomplete regeneration may not have fully cleaned the adsorbing array. Partial pressures of non-condensables (hydrogen, neon or helium) may remain.	Regenerate the cryopump as described in <b>Section 3 - Regeneration</b> .

## Section 5 - Maintenance Procedures

### Helium Circuit Decontamination

Contamination of the helium-gas circuit is indicated by sluggish or intermittent operation (ratchetting) of the cold head drive mechanism. With severe contamination the cold head drive may seize and fail to operate. One of the major sources of contamination is using helium gas of less than the required purity. When performing the decontamination process, use only 99.999% pure-helium gas, and the regulator and charging line must be properly connected and purged.

This decontamination procedure will remove contaminants from the cold head and/or compressor, thereby restoring system performance. The cold-trapping of contaminants inside the cold head during this procedure will also decontaminate the compressor if the contamination of the system is not severe. Separate decontamination of the compressor is required whenever the compressor has been opened to atmosphere, or the pressure dropped to zero.

### Cryo-Torr Cryopump Decontamination Procedures

*NOTE: Refer also to the appropriate Compressor Manual.*

1. Cool down the cryopump and operate it for one to three hours. If the system will not cool down, proceed to step 2. Operating the cryopump will isolate the contaminants by "freezing" them in the cold head. The contaminants in the helium-gas circuit of the cryopump tend to become frozen inside the cold head. The longer the cryopump is operated beyond the one-hour period, the greater is the amount of contamination that becomes isolated inside the cold head.
2. Shut down the cryopump as described in **Section 2 - Installation**.
3. *Immediately* disconnect the helium supply and return lines from the gas-supply and gas-return connectors at the rear of the compressor. Leave them attached to the cold head.
4. Attach the maintenance manifold to the disconnected ends of the return and supply lines.

5. Reduce the pressure in the cold head to a level of 30 psig by using the maintenance manifold. Reducing the pressure in the cold head to below 30 psig (200 kPa) may introduce more contaminants into the helium circuit.

If you only have the manual regeneration option, turn the cryopump OFF and open the purge valve until the second stage temperature reaches 290K.

6. Attach a two-stage regulator (0-3000/0-400 psig) and charging line to a helium bottle (99.999% pure). DO NOT OPEN THE BOTTLE VALVE AT THIS TIME. Purge the regulator and charging line as introduced in steps a through d below. Do *not* use helium gas that is *less than 99.999% pure*.
  - a. Open the regulator a small amount by turning the adjusting knob clockwise until it contacts the diaphragm; then, turn approximately 1/8 to 1/4 turn more, so that the regulator is barely open.
  - b. Slowly open the bottle valve, and purge the regulator and line for 10 to 15 seconds. Turn the regulator knob counter-clockwise until the helium stops flowing.
  - c. Loosely connect the charge line to the 1/8-inch Hoke valve on the maintenance manifold.
  - d. Purge the charge line again, as in step a, for 30 seconds, and tighten the charge line flare fitting onto the Hoke valve while the helium is flowing.

This procedure is required to ensure that both the regulator and the charging line will be purged of air and that the air trapped in the regulator will not diffuse back into the helium bottle. For best results, CTI-CRYOGENICS suggests a dedicated helium bottle, regulator, and line, which are never separated, for adding helium.

7. Perform in sequence:
  - a. Backfill the cold head with helium to a static charge pressure of 195-205 psig (1345-1415 kPa) by adjusting the regulator to the required pressure, and opening the Hoke valve on the manifold. Close the Hoke valve when the pressure is correct.
  - b. Depressurize the cold head to 30 and 50 psig 200 and 330 kPa) by slowly opening the ball valve and allowing the helium to bleed out slowly. Do *not* reduce the pressure to *less than 30 psig* or the cold head may be further contaminated.

- c. Perform the flushing steps a and b four more times.
  - d. Pressurize the cold head to a static charge pressure of 195-205 psig (1345-1415 kPa) and run the cold head drive motor for 10 to 30 seconds.
  - e. Perform steps b through d four more times for a total of 25 flushes and 5 drive-motor runs.
8. Verify that the cold head is pressurized to the static charge pressure of 195-205 psig (1345-1415 kPa).
  9. Disconnect the maintenance manifold from the helium return and supply lines.
  10. Reconnect the helium return and supply lines to the return and supply connectors at the rear of the compressor. The cryopump is now ready for operation.

## Cleaning the Cryo-Torr Cryopump

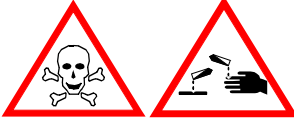
	<b>WARNING</b>
If the cryopump has been used to pump toxic or dangerous materials, you must take adequate precautions to safeguard personnel.	

Cleaning the arrays or other interior surfaces of the cryopump vacuum vessel is seldom required because dust build-up does not affect performance, and the special alloy copper cryo-condensing arrays are nickel plated for corrosion resistance.

If you wish to clean the arrays and other interior surfaces, follow the procedures below.

1. Confirm that an adequate supply of indium gasket material, P/N 3543738P001, is available to replace gaskets inadvertently damaged during disassembly.
2. Carefully disassemble the components in the vacuum vessel, including the arrays and radiation shield, to avoid damage to the indium gaskets.
3. Clean the interior surface of the vacuum vessel, the 80K condensing array, and the 80K radiation shield as follows:
  - a. Wash each item in strong soap or detergent solution and hot water.

- b. Rinse the item in *clean hot water*.
- c. Air or oven dry all items at 150°F (66°C) maximum before reinstalling into the cryopump.

**CAUTION**

Do not clean the 15K cryo-adsorbing array, because you may severely contaminate the adsorbent in the cleaning process.

4. Wearing lint-free gloves, reassemble the cryopump. Replace any indium gasket damaged during disassembly with a gasket cut from indium gasket material.
5. Torque all screws that compress indium gaskets for a minimum of 5 seconds to allow proper gasket seating:

**Table 5-1: Indium Gasket Screw Torque Specifications**

Screw Thread	Torque (Inch-Pounds)
No. 4-40	11
No. 6-32	20



# Appendix A - Customer Support Centers

## Introduction

Refer to Table A-1 for the nearest Customer Support Center for technical assistance or service. North American customers may call 800-FOR-GUTS (800-367-4887) 24 hours a day, seven days a week. All other customers must call their local Customer Support Center.

Please have the following information available when calling so that we may assist you:

- Product Part Number
- Product Serial Number
- Product Application
- Specific Problem Area
- Hours of Operation
- Equipment Type
- Vacuum System Brand/Model/Date of Manufacture

For your convenience, you may also e-mail us at:

*[techsupport@helixtechnology.com](mailto:techsupport@helixtechnology.com)*

Visit us at our corporate website:

*[www.helixtechnology.com](http://www.helixtechnology.com)*

**Table A-1: Customer Support Centers**

<p><b>United States and Canada</b></p> <p>Helix Technology Corporation            Customer Response Center            Nine Hampshire Street            Mansfield, Massachusetts 02048 U.S.A.            Tel: 508-337-5000            Tel: 800-379-7224 (within USA)            Fax: 508-337-5169</p> <p>Dial: 800-FOR-GUTS (800-367-4887)            24 hours a day, seven days a week</p>	<p><b>United States and Canada</b></p> <p>Helix Technology Corporation            3350 Montgomery Drive            Santa Clara, California 95054 U.S.A.            Tel: 408-592-5940            Tel: 800-324-6449 (within USA)            Fax: 408-988-6630</p> <p>Dial: 800-FOR-GUTS (800-367-4887)            24 hours a day, seven days a week</p>
<p><b>United States and Canada</b></p> <p>Helix Technology Corporation            4120 Freidrich Lane            Suite 600            Austin, Texas 78744 U.S.A.            Tel: 512-912-2800            Tel: 800-324-6445 (within USA)            Fax: 512-912-2888</p> <p>Dial: 800-FOR-GUTS (800-367-4887)            24 hours a day, seven days a week</p>	<p><b>United States and Canada</b></p> <p>Helix Technology Corporation            Colorado Operations            6450 Dry Creek Parkway            Longmont, Colorado 80503 U.S.A.            Tel: 303-652-4400            Tel: 800-776-6543 (within USA)            Fax: 303-652-2844</p> <p>Dial: 800-FOR-GUTS (800-367-4887)            24 hours a day, seven days a week</p>

**Table A-1: Customer Support Centers (Continued)**

<p><b>Germany, Italy, Denmark, Switzerland, Holland, Norway, The Netherlands</b></p> <p>Helix Technology Corporation          Haasstrasse 15          D-64293 Darmstadt          Germany          Tel: +(49) 6151-959-55          Fax: +(49) 6151-959-57</p> <p>Dial: +(49) 6151-959-55          24 hours a day, seven days a week</p>	<p><b>France, Spain, Portugal, Greece</b></p> <p>Helix Technology          Domaine Technologique de Saclay          4, rue Rene Razel, Bât Apollo          F-91892 Orsay Cedex          France          Tel: +(33) 1-6935-2600          Fax: +(33) 1-6985-3725</p> <p>Dial: +(33) 1-6935-2600          24 hours a day, seven days a week</p>
<p><b>United Kingdom, Ireland, Sweden, N. Ireland</b></p> <p>Helix Technology Corporation          Fleming Road          Kirkton Campus          Livingston, West Lothian          Scotland EH54 7BN          Tel: +(44) 1-506-460017          Fax: +(44) 1-506-411122</p> <p>Dial: +(44) 1-506-460017          24 hours a day, seven days a week</p>	<p><b>Japan</b></p> <p>Helix Technology Corporation          Queens Tower A 14F          3-1, Minatomirai 2-chome          Nishi-ku, Yokohama          Japan 220-6014          Tel: +(81) 45-682-5470          Fax: +(81) 45-682-5475</p> <p>Dial: +(81) 0120-60-4887          24 hours a day, seven days a week</p>
<p><b>Korea</b></p> <p>Helix Technology          Zeus Company, Ltd.          Zeus Building          3-16, Yangjae-Dong, Socho-ku          Seoul 137-130, Korea          Tel: +(82) 2-577-3181/3186          Fax: +(82) 2-576-3199</p> <p>Dial: +(82) 2-577-3181          24 hours a day, seven days a week</p>	<p><b>Taiwan</b></p> <p>Helix Vacuum Technology Limited          4F-1 No. 81 Shui Lee Road          Hsin-Chu 300, Taiwan</p> <p>Tel: +(886) (3) 572-3999          Fax: +(886) (3) 571-7670</p> <p>Dial: +(886) (3) 516-9022          24 hours a day, seven days a week</p>

**Table A-1: Customer Support Centers (Continued)**

<p><b>China</b></p> <p>Helix Technology Corporation          Tritex International Company          Da An Square, 9A Middle Bldg          829 Yan An Middle Road          Shanghai, 200040          China          Tel: +(86) 21-6279-1389          Fax: +(86) 21-6247-1539</p> <p>Dial +(86) 21-6279-1389          24 hours a day, seven days a week</p>	<p><b>Australia, New Zealand, Tasmania</b></p> <p>Helix Technology Corporation          CTI-Cryogenics Products          AVT Services Pte. Ltd.          Unit 1, 12 Pioneer Avenue          Thornleigh NSW 2120          Sydney, Australia          Tel: +(612) 9-4810748          Fax: +(612) 9-4810910</p> <p>Dial: +(612) 9-4810748          24 hours a day, seven days a week</p>
<p><b>Australia, New Zealand, Tasmania</b></p> <p>Helix Technology Corporation          Granville-Phillips Products          Stanton Scientific          2/6 Jonson St.          Byron Bay, NSW 2481          Australia          Tel: +(61) 66-856-902          Fax: +(61) 66-858-530</p>	<p><b>Singapore, Malaysia, Philippines, Indonesia</b></p> <p>Helix Technology Corporation          APP Systems Services Pte Ltd.          2 Corporation Road          #06-14 Corporation Place          Singapore 2261          Tel: +(65) 268-2024          Fax: +(65) 268-6621</p> <p>Dial: +(65) 268-2024          24 hours a day, seven days a week</p>

**Table A-1: Customer Support Centers (Continued)**

<p><b>India</b></p> <p>Helix Technology Corporation          CTI-Cryogenics Products          Goodwill Cryogenics Enterprise          213 Nirman, Sec. 17, Vashi          New Bombay, 400703          India          Tel: +(91) 22-7632906          Fax: +(91) 22-7822769</p> <p>Dial: +(91) 22-7632906          24 hours a day, seven days a week</p>	<p><b>India</b></p> <p>Helix Technology Corporation          Granville-Phillips Products          Ashwini Enterprises          C-2/13/03, Sector-16, Vashi          New Bombay 400 705          India          Tel: +(91) 22-766 1107          Fax: +(91) 22-766 2631</p>
<p><b>Israel</b></p> <p>Helix Technology Corporation          CTI-Cryogenics Products          Vacuum System &amp; Technology Ltd.          P.O. Box 4137          Petach Tikva 49130          Israel          Tel: +(972) 3-9247710          Fax: +(972) 3-9247711</p> <p>Dial: +(972) 3-9247710          24 hours a day, seven days a week</p>	<p><b>Israel</b></p> <p>Helix Technology Corporation          Granville-Phillips Products          El-Tan Technologies          P.O. Box 1020          Hod-Hasharon 45110          Israel          Tel: +(972) 9-740-5551          Fax: +(972) 9-740-6690</p>