

**MKS Type PDR-C-1C/2C  
Power Supply  
Digital Readout**

*Copyright © 1997 by MKS Instruments, Inc.*

*All rights reserved. No part of this work may be reproduced or transmitted in any form or by any means, electronic or mechanical, including photocopying and recording, or by any information storage or retrieval system, except as may be expressly permitted in writing by MKS Instruments, Inc.*

Baratron® is a registered trademark of MKS Instruments, Inc., Andover, MA

## Table of Contents

Safety Information.....	1
Symbols Used in This Instruction Manual.....	1
Symbols Found on the Unit.....	2
Safety Procedures and Precautions .....	3
Sicherheitshinweise .....	5
In dieser Betriebsanleitung vorkommende Symbole .....	5
Am Gerät angebrachte Symbole .....	6
Sicherheitsvorschriften und Vorsichtsmaßnahmen.....	7
Informations relatives à la sécurité .....	9
Symboles utilisés dans ce manuel d'utilisation .....	9
Symboles apparaissant sur l'appareil.....	10
Mesures de sécurité et mises en garde .....	11
Información sobre seguridad.....	13
Símbolos usados en el manual de instrucciones .....	13
Símbolos que aparecen en la unidad .....	14
Procedimientos y precauciones de seguridad.....	15
Chapter One: General Information.....	17
Introduction .....	17
How This Manual is Organized.....	18
Customer Support.....	18
Chapter Two: Installation.....	19
How To Unpack the Type PDR-C-1C/2C Unit.....	19
Unpacking Checklist .....	19
Product Location and Requirements .....	20
Operating Environmental Requirements.....	20
Dimensions.....	20
Setup.....	22
Grounds .....	22

Chapter Three: Overview .....	23
Rear Panel Connections and Controls .....	23
Pressure Sensor Connector .....	23
Decimal Point Selector .....	23
Power Interface Connector .....	24
Interface Connector (J118) .....	24
BCD Output Connector .....	24
Set point Channel Select Switches .....	24
Front Panel Controls and Indicators .....	25
Power Switch .....	25
Display (DVM) .....	25
Zero Adjust Control .....	25
Set Point Adjust Controls .....	25
Read Set Point Switch .....	25
Set Point Relay Indicator Lamps .....	25
Engineering Units Selection Switch .....	25
x10 <sup>-3</sup> Lamp .....	25
Channel Select/Remote/Auto Switch .....	26
Interface Connector (J118) Pinout .....	27
Pressure Sensor Terminal Block Connections .....	28
Chapter Four: Theory of Operation .....	29
Pressure Signal .....	29
Set Points .....	29
Overrange Comparator .....	29
Power Supply .....	29
Pressure Level Comparators .....	30
Channel Selector / Function Switch .....	30
Chapter Five: Maintenance .....	31
General Information .....	31
Fault Isolation .....	31
Power Supply .....	32
Pressure Signal Amplification and Readout .....	32

---

Set Point Circuits.....	35
Channel Selection Circuits.....	35
Appendix A: Product Specifications .....	37
Physical Specifications.....	37
Environmental Specifications .....	37
Electrical Specifications.....	37
Set Point Specifications.....	38
Appendix B: Model Code Explanation .....	39
Model Code .....	39
Appendix C: BCD Option .....	41
General Information .....	41
Index .....	43



## List of Figures and Tables

### **Figures**

Figure 1: Front Panel of the Type PDR-C-1C Unit.....	20
Figure 2: Rear Panel of the Type PDR-C-1C Unit.....	20
Figure 3: Front Panel of the Type PDR-C-2C Unit.....	21
Figure 4: Rear Panel of the Type PDR-C-2C Unit.....	21
Figure 5: Inserting Two Resistors to Replace the Pressure Sensor Signal .....	33

### **Tables**

Table 1: Definition of Symbols Found on the Unit.....	2
Tabelle 2: Definitionen der am Gerät angebrachten Symbole .....	6
Tableau 3 : Définition des symboles apparaissant sur l'appareil .....	10
Tabla 4 : Definición de los símbolos que aparecen en la unidad .....	14
Table 5: Baratron Transducers Supported by the PDR-C Readouts .....	17
Table 6: Sensor Cable Identification .....	22
Table 7: Decimal Point Selector Switch .....	23
Table 8: Interface Connector Pinout .....	27
Table 9: Pressure Sensor Terminal Block Connections.....	28
Table 10: Correct Trimmer for Selected Engineering Units .....	34
Table 11: BCD Connector Pinout .....	41





## Safety Information

### Symbols Used in This Instruction Manual

Definitions of WARNING, CAUTION, and NOTE messages used throughout the manual.

**Warning**



---

The **WARNING** sign denotes a hazard. It calls attention to a procedure, practice, condition, or the like, which, if not correctly performed or adhered to, could result in injury to personnel.

---

**Caution**



---

The **CAUTION** sign denotes a hazard. It calls attention to an operating procedure, practice, or the like, which, if not correctly performed or adhered to, could result in damage to or destruction of all or part of the product.

---

**Note**



---

The **NOTE** sign denotes important information. It calls attention to a procedure, practice, condition, or the like, which is essential to highlight.

---

## Symbols Found on the Unit

The following table describes symbols that may be found on the unit.















Definition of Symbols Found on the Unit			
			
On (Supply) IEC 417, No.5007	Off (Supply) IEC 417, No.5008	Earth (ground) IEC 417, No.5017	Protective earth (ground) IEC 417, No.5019
			
Frame or chassis IEC 417, No.5020	Equipotentiality IEC 417, No.5021	Direct current IEC 417, No.5031	Alternating current IEC 417, No.5032
			
Both direct and alternating current IEC 417, No.5033-a	Class II equipment IEC 417, No.5172-a	Three phase alternating current IEC 617-2 No.020206	
			
Caution, refer to accompanying documents ISO 3864, No.B.3.1	Caution, risk of electric shock ISO 3864, No.B.3.6	Caution, hot surface IEC 417, No.5041	

Table 1: Definition of Symbols Found on the Unit

## **Safety Procedures and Precautions**

**The following general safety precautions must be observed during all phases of operation of this instrument. Failure to comply with these precautions or with specific warnings elsewhere in this manual violates safety standards of intended use of the instrument and may impair the protection provided by the equipment. MKS Instruments, Inc. assumes no liability for the customer's failure to comply with these requirements.**

### **DO NOT SUBSTITUTE PARTS OR MODIFY INSTRUMENT**

Do not install substitute parts or perform any unauthorized modification to the instrument. Return the instrument to an MKS Calibration and Service Center for service and repair to ensure that all safety features are maintained.

### **SERVICE BY QUALIFIED PERSONNEL ONLY**

Operating personnel must not remove instrument covers. Component replacement and internal adjustments must be made by qualified service personnel only.

### **GROUNDING THE PRODUCT**

This product is grounded through the grounding conductor of the power cord. To avoid electrical shock, plug the power cord into a properly wired receptacle before connecting it to the product input or output terminals. A protective ground connection by way of the grounding conductor in the power cord is essential for safe operation.

### **DANGER ARISING FROM LOSS OF GROUND**

Upon loss of the protective-ground connection, all accessible conductive parts (including knobs and controls that may appear to be insulating) can render an electrical shock.

### **GROUND AND USE PROPER ELECTRICAL FITTINGS**

Dangerous voltages are contained within this instrument. All electrical fittings and cables must be of the type specified, and in good condition. All electrical fittings must be properly connected and grounded.

### **USE THE PROPER POWER CORD**

Use only a power cord that is in good condition and which meets the input power requirements specified in the manual.

Use only a detachable cord set with conductors that have a cross-sectional area equal to or greater than 0.75 mm<sup>2</sup>. The power cable should be approved by a qualified agency such as VDE, Semko, or SEV.

**USE THE PROPER POWER SOURCE**

This product is intended to operate from a power source that does not apply more voltage between the supply conductors, or between either of the supply conductors and ground, than that specified in the manual.

**USE THE PROPER FUSE**

Use only a fuse of the correct type, voltage rating, and current rating, as specified for your product.

**DO NOT OPERATE IN EXPLOSIVE ATMOSPHERES**

To avoid explosion, do not operate this product in an explosive environment unless it has been specifically certified for such operation.

**HIGH VOLTAGE DANGER**

High voltage is present in the cable, and in the sensor when the controller is turned on.

## Sicherheitshinweise

### In dieser Betriebsanleitung vorkommende Symbole

Definition der mit WARNUNG!, VORSICHT! und HINWEIS überschriebenen Abschnitte in dieser Betriebsanleitung.

**Warnung!**



---

Das Symbol **WARNUNG!** weist auf eine Gefahrenquelle hin. Es macht auf einen Arbeitsablauf, eine Arbeitsweise, einen Zustand oder eine sonstige Gegebenheit aufmerksam, deren unsachgemäße Ausführung bzw. ungenügende Berücksichtigung zu Körperverletzung führen kann.

---

**Vorsicht!**



---

Das Symbol **VORSICHT!** weist auf eine Gefahrenquelle hin. Es macht auf einen Bedienungsablauf, eine Arbeitsweise oder eine sonstige Gegebenheit aufmerksam, deren unsachgemäße Ausführung bzw. ungenügende Berücksichtigung zu einer Beschädigung oder Zerstörung des Produkts oder von Teilen des Produkts führen kann.

---

**Hinweis**



---

Das Symbol **HINWEIS** weist auf eine wichtige Mitteilung hin, die auf einen Arbeitsablauf, eine Arbeitsweise, einen Zustand oder eine sonstige Gegebenheit von besonderer Wichtigkeit aufmerksam macht.

---

## Am Gerät angebrachte Symbole

Der untenstehenden Tabelle sind die Bedeutungen der Symbole zu entnehmen, die an dem Gerät angebracht sind.















Definitionen der am Gerät angebrachten Symbole			
 Ein (Netz) IEC 417, Nr. 5007	 Aus (Netz) IEC 417, Nr. 5008	 Erde IEC 417, Nr. 5017	 Schutzleiter IEC 417, Nr. 5019
 Rahmen oder Chassis IEC 417, Nr. 5020	 Äquipotentialanschluß IEC 417, Nr. 5021	 Gleichstrom IEC 417, Nr. 5031	 Wechselstrom IEC 417, Nr. 5032
 Wechselstrom und Gleichstrom IEC 417, Nr. 5033-a	 Geräteklasse II IEC 417, Nr. 5172-a	 Drehstrom IEC 617-2 Nr. 020206	
 Vorsicht! Bitte Begleitdokumente lesen! ISO 3864, Nr. B.3.1	 Vorsicht! Stromschlaggefahr! ISO 3864, Nr. B.3.6	 Vorsicht! Heiße Fläche! IEC 417, Nr. 5041	

Tabelle 2: Definitionen der am Gerät angebrachten Symbole

## **Sicherheitsvorschriften und Vorsichtsmaßnahmen**

**Die untenstehenden allgemeinen Sicherheitsvorschriften sind bei allen Betriebsphasen dieses Instruments zu befolgen. Jede Mißachtung dieser Sicherheitsvorschriften oder sonstiger spezifischer Warnhinweise in dieser Betriebsanleitung stellt eine Zuwiderhandlung der für dieses Instrument geltenden Sicherheitsstandards dar und kann die an diesem Instrument vorgesehenen Schutzvorrichtungen unwirksam machen. MKS Instruments, Inc. haftet nicht für eine Mißachtung dieser Sicherheitsvorschriften seitens des Kunden.**

### **Keine Teile austauschen und keine Veränderungen vornehmen!**

Bauen Sie in das Instrument keine Ersatzteile ein, und nehmen Sie keine eigenmächtigen Änderungen am Gerät vor! Schicken Sie das Instrument zu Wartungs- und Reparaturzwecken an einen MKS-Kalibrierungs- und -Kundendienst ein! Dadurch wird sichergestellt, daß alle Sicherheitseinrichtungen voll funktionsfähig bleiben.

### **Wartung nur durch qualifizierte Fachleute!**

Das Gehäuse des Instruments darf vom Bedienpersonal nicht geöffnet werden. Das Auswechseln von Bauteilen und das Vornehmen von internen Einstellungen ist nur von qualifizierten Fachleuten durchzuführen.

### **Produkt erden!**

Dieses Produkt ist mit einer Erdleitung und einem Schutzkontakt am Netzstecker versehen. Um der Gefahr eines elektrischen Schlages vorzubeugen, ist das Netzkabel an einer vorschriftsmäßig geerdeten Schutzkontaktsteckdose anzuschließen, bevor es an den Eingangs- bzw. Ausgangsklemmen des Produkts angeschlossen wird. Das Instrument kann nur sicher betrieben werden, wenn es über den Erdleiter des Netzkabels und einen Schutzkontakt geerdet wird.

### **Gefährdung durch Verlust der Schutzerdung!**

Geht die Verbindung zum Schutzleiter verloren, besteht an sämtlichen zugänglichen Teilen aus stromleitendem Material die Gefahr eines elektrischen Schlages. Dies gilt auch für Knöpfe und andere Bedienelemente, die dem Anschein nach isoliert sind.

### **Erdung und Verwendung geeigneter elektrischer Armaturen!**

In diesem Instrument liegen gefährliche Spannungen an. Alle verwendeten elektrischen Armaturen und Kabel müssen dem angegebenen Typ entsprechen und sich in einwand-freiem Zustand befinden. Alle elektrischen Armaturen sind vorschriftsmäßig anzubringen und zu erden.

### **Richtiges Netzkabel verwenden!**

Das verwendete Netzkabel muß sich in einwandfreiem Zustand befinden und den in der Betriebsanleitung enthaltenen Anschlußwerten entsprechen.

Das Netzkabel muß abnehmbar sein. Der Querschnitt der einzelnen Leiter darf nicht weniger als  $0,75 \text{ mm}^2$  betragen. Das Netzkabel sollte einen Prüfvermerk einer zuständigen Prüfstelle tragen, z.B. VDE, Semko oder SEV.

### **Richtige Stromquelle verwenden!**

Dieses Produkt ist für eine Stromquelle vorgesehen, bei der die zwischen den Leitern bzw. zwischen jedem der Leiter und dem Masseleiter anliegende Spannung den in dieser Betriebsanleitung angegebenen Wert nicht überschreitet.

### **Richtige Sicherung benutzen!**

Es ist eine Sicherung zu verwenden, deren Typ, Nennspannung und Nennstromstärke den Angaben für dieses Produkt entsprechen.

### **Gerät nicht in explosiver Atmosphäre benutzen!**

Um der Gefahr einer Explosion vorzubeugen, darf dieses Gerät nicht in der Nähe explosiver Stoffe eingesetzt werden, sofern es nicht ausdrücklich für diesen Zweck zertifiziert worden ist.

### **Hochspannungsgefahr!**

Bei eingeschaltetem Steuerteil liegt im Kabel und im Sensor Hochspannung an.



## Informations relatives à la sécurité

### Symboles utilisés dans ce manuel d'utilisation

Définition des indications AVERTISSEMENT, ATTENTION et REMARQUE utilisées dans ce manuel.

**Avertissement**



---

L'indication **AVERTISSEMENT** signale un danger potentiel. Elle est destinée à attirer l'attention sur une procédure, une utilisation, une situation ou toute autre chose présentant un risque de blessure en cas d'exécution incorrecte ou de non-respect des consignes.

---

**Attention**



---

L'indication **ATTENTION** signale un danger potentiel. Elle est destinée à attirer l'attention sur une procédure, une utilisation, une situation ou toute autre chose présentant un risque d'endommagement ou de dégât d'une partie ou de la totalité de l'appareil en cas d'exécution incorrecte ou de non-respect des consignes.

---

**Remarque**



---

L'indication **REMARQUE** signale des informations importantes. Elle est destinée à attirer l'attention sur une procédure, une utilisation, une situation ou toute autre chose présentant un intérêt particulier.

---

## Symboles apparaissant sur l'appareil

Le tableau suivant décrit les symboles apparaissant sur l'appareil.















Définition des symboles apparaissant sur l'appareil			
			
Marche (sous tension) IEC 417, No. 5007	Arrêt (hors tension) IEC 417, No. 5008	Terre (masse) IEC 417, No. 5017	Terre de protection (masse) IEC 417, No. 5019
			
Masse IEC 417, No. 5020	Equipotentialité IEC 417, No. 5021	Courant continu IEC 417, No. 5031	Courant alternatif IEC 417, No. 5032
			
Courant continu et alternatif IEC 417, No. 5033-a	Matériel de classe II IEC 417, No. 5172-a	Courant alternatif triphase IEC 617-2 No. 020206	
			
Attention : se reporter à la documentation ISO 3864, No. B.3.1	Attention : risque de secousse électrique ISO 3864, No. B.3.6	Attention : surface brûlante IEC 417, No. 5041	

Tableau 3 : Définition des symboles apparaissant sur l'appareil

## **Mesures de sécurité et mises en garde**

**Prendre toutes les précautions générales suivantes pendant toutes les phases d'utilisation de cet appareil. Le non-respect de ces précautions ou des avertissements contenus dans ce manuel entraîne une violation des normes de sécurité relatives à l'utilisation de l'appareil et le risque de réduire le niveau de protection fourni par l'appareil. MKS Instruments, Inc. ne prend aucune responsabilité pour les conséquences de tout non-respect des consignes de la part de ses clients.**

### **NE PAS SUBSTITUER DES PIÈCES OU MODIFIER L'APPAREIL**

Ne pas utiliser de pièces détachées autres que celles vendues par MKS Instruments, Inc. ou modifier l'appareil sans l'autorisation préalable de MKS Instruments, Inc. Renvoyer l'appareil à un centre d'étalonnage et de dépannage MKS pour tout dépannage ou réparation afin de s'assurer que tous les dispositifs de sécurité sont maintenus.

### **DÉPANNAGE EFFECTUÉ UNIQUEMENT PAR UN PERSONNEL QUALIFIÉ**

L'opérateur de l'appareil ne doit pas enlever le capot de l'appareil. Le remplacement des composants et les réglages internes doivent être effectués uniquement par un personnel d'entretien qualifié.

### **MISE À LA TERRE DE L'APPAREIL**

Cet appareil est mis à la terre à l'aide du fil de terre du cordon d'alimentation. Pour éviter tout risque de secousse électrique, brancher le cordon d'alimentation sur une prise de courant correctement câblée avant de le brancher sur les bornes d'entrée ou de sortie de l'appareil. Une mise à la terre de protection à l'aide du fil de terre du cordon d'alimentation est indispensable pour une utilisation sans danger de l'appareil.

### **DANGER LIÉ À UN DÉFAUT DE TERRE**

En cas de défaut de terre, toutes les pièces conductrices accessibles (y compris les boutons de commande ou de réglage qui semblent être isolés) peuvent être source d'une secousse électrique.

### **MISE À LA TERRE ET UTILISATION CORRECTE D'ACCESSOIRES ÉLECTRIQUES**

Des tensions dangereuses existent à l'intérieur de l'appareil. Tous les accessoires et les câbles électriques doivent être conformes au type spécifié et être en bon état. Tous les accessoires électriques doivent être correctement connectés et mis à la terre.

### **UTILISATION D'UN CORDON D'ALIMENTATION APPROPRIÉ**

Utiliser uniquement un cordon d'alimentation en bon état et conforme aux exigences de puissance d'entrée spécifiées dans le manuel.

Utiliser uniquement un cordon d'alimentation amovible avec des conducteurs dont la section est égale ou supérieure à 0,75 mm<sup>2</sup>. Le cordon d'alimentation doit être approuvé par un organisme compétent tel que VDE, Semko ou SEV.

### **UTILISATION D'UNE ALIMENTATION APPROPRIÉE**

Cet appareil est conçu pour fonctionner en s'alimentant sur une source de courant électrique n'appliquant pas une tension entre les conducteurs d'alimentation, ou entre les conducteurs d'alimentation et le conducteur de terre, supérieure à celle spécifiée dans le manuel.

### **UTILISATION D'UN FUSIBLE APPROPRIÉ**

Utiliser uniquement un fusible conforme au type, à la tension nominale et au courant nominal spécifiés pour l'appareil.

### **NE PAS UTILISER DANS UNE ATMOSPHÈRE EXPLOSIVE**

Pour éviter tout risque d'explosion, ne pas utiliser l'appareil dans une atmosphère explosive à moins qu'il n'ait été approuvé pour une telle utilisation.

### **DANGER DE HAUTE TENSION**

Une haute tension est présente dans le câble et dans le capteur lorsque le contrôleur est sous tension.

## Información sobre seguridad

### Símbolos usados en el manual de instrucciones

Definiciones de los mensajes de ADVERTENCIA, PRECAUCIÓN Y OBSERVACIÓN usados en el manual.

**Advertencia**



---

El símbolo de **ADVERTENCIA** indica un riesgo. **Pone de relieve un procedimiento, práctica, condición, etc., que, de no realizarse u observarse correctamente, podría causar lesiones a los empleados.**

---

**Precaución**



---

El símbolo de **PRECAUCIÓN** indica un riesgo. **Pone de relieve un procedimiento, práctica, etc., de tipo operativo que, de no realizarse u observarse correctamente, podría causar desperfectos al instrumento, o llegar incluso a causar su destrucción total o parcial.**

---

**Observación**



---

El símbolo de **OBSERVACIÓN** indica información de importancia. **Pone de relieve un procedimiento, práctica, condición, etc., cuyo conocimiento resulta esencial.**

---

## Símbolos que aparecen en la unidad

En la tabla que figura a continuación se indican los símbolos que aparecen en la unidad.















Definición de los símbolos que aparecen en la unidad			
			
Encendido (alimentación eléctrica) IEC 417, N.º 5007	Apagado (alimentación eléctrica) IEC 417, N.º 5008	Puesta a tierra IEC 417, N.º 5017	Protección a tierra IEC 417, N.º 5019
			
Caja o chasis IEC 417, N.º 5020	Equipotencialidad IEC 417, N.º 5021	Corriente continua IEC 417, N.º 5031	Corriente alterna IEC 417, N.º 5032
			
Corriente continua y alterna IEC 417, N.º 5033-a	Equipo de clase II IEC 417, N.º 5172-a	Corriente alterna trifásica IEC 617-2 N.º 020206	
			
Precaución. Consultar los documentos adjuntos ISO 3864, N.º B.3.1	Precaución. Riesgo de descarga eléctrica ISO 3864, N.º B.3.6	Precaución. Superficie caliente IEC 417, N.º 5041	

Tabla 4 : Definición de los símbolos que aparecen en la unidad

## **Procedimientos y precauciones de seguridad**

**Las precauciones generales de seguridad que figuran a continuación deben observarse durante todas las fases de funcionamiento del presente instrumento. La no observancia de dichas precauciones, o de las advertencias específicas a las que se hace referencia en el manual, contraviene las normas de seguridad referentes al uso previsto del instrumento y podría impedir la protección que proporciona el instrumento. MKS Instruments, Inc., no asume responsabilidad alguna en caso de que el cliente haga caso omiso de estos requerimientos.**

### **NO UTILIZAR PIEZAS NO ORIGINALES NI MODIFICAR EL INSTRUMENTO**

No se debe instalar piezas que no sean originales ni modificar el instrumento sin autorización. Para garantizar que las prestaciones de seguridad se observen en todo momento, enviar el instrumento al Centro de servicio y calibración de MKS cuando sea necesaria su reparación y servicio de mantenimiento.

### **REPARACIONES EFECTUADAS ÚNICAMENTE POR TÉCNICOS ESPECIALIZADOS**

Los operarios no deben retirar las cubiertas del instrumento. El cambio de piezas y los reajustes internos deben efectuarlos únicamente técnicos especializados.

### **PUESTA A TIERRA DEL INSTRUMENTO**

Este instrumento está puesto a tierra por medio del conductor de tierra del cable eléctrico. Para evitar descargas eléctricas, enchufar el cable eléctrico en una toma debidamente instalada, antes de conectarlo a las terminales de entrada o salida del instrumento. Para garantizar el uso sin riesgos del instrumento resulta esencial que se encuentre puesto a tierra por medio del conductor de tierra del cable eléctrico.

### **PELIGRO POR PÉRDIDA DE LA PUESTA A TIERRA**

Si se pierde la conexión protectora de puesta a tierra, todas las piezas conductoras a las que se tiene acceso (incluidos los botones y mandos que pudieran parecer estar aislados) podrían producir descargas eléctricas.

### **PUESTA A TIERRA Y USO DE ACCESORIOS ELÉCTRICOS ADECUADOS**

Este instrumento funciona con voltajes peligrosos. Todos los accesorios y cables eléctricos deben ser del tipo especificado y mantenerse en buenas condiciones. Todos los accesorios eléctricos deben estar conectados y puestos a tierra del modo adecuado.

### **USAR EL CABLE ELÉCTRICO ADECUADO**

Usar únicamente un cable eléctrico que se encuentre en buenas condiciones y que cumpla los requisitos de alimentación de entrada indicados en el manual.

Usar únicamente un cable desmontable instalado con conductores que tengan un área de sección transversal equivalente o superior a 0,75mm<sup>2</sup>. El cable eléctrico debe estar aprobado por una entidad autorizada como, por ejemplo, VDE, Semko o SEV.

### **USAR LA FUENTE DE ALIMENTACIÓN ELÉCTRICA ADECUADA**

Este instrumento debe funcionar a partir de una fuente de alimentación eléctrica que no aplique más voltaje entre los conductores de suministro, o entre uno de los conductores de suministro y la puesta a tierra, que el que se especifica en el manual.

### **USAR EL FUSIBLE ADECUADO**

Usar únicamente un fusible del tipo, clase de voltaje y de corriente adecuados, según lo que se especifica para el instrumento.

### **EVITAR SU USO EN ENTORNOS EXPLOSIVOS**

Para evitar el riesgo de explosión, no usar este instrumento o en un entorno explosivo, a no ser que haya sido certificado para tal uso.

### **PELIGRO POR ALTO VOLTAJE**

Cuando el controlador está encendido, se registra alto voltaje en el cable y en el sensor.



## Chapter One: General Information

### Introduction

The MKS Type PDR-C-1C and PDR-C-2C are power supply and digital readouts which are packaged in standard half-rack mount units. The PDR-C-2C is designed to provide power for, and accept the outputs from two pressure sensors. The PDR-C-1C is identical to the -2C except the -1C is designed for operation with one pressure sensor.

The power supply for both the -1C and -2C is capable of providing  $\pm 15$  VDC at up to 600 mA. This will provide enough power for two MKS Baratrons, including those listed in Table 5, or for any electronic manometer with similar input requirements.

<b>Baratron Transducers Supported by the PDR-C Readouts</b>		
121	223	624
122	224	625
124	422	626
127	427	627
128	622	628 (only one)
221	623	722

Table 5: Baratron Transducers Supported by the PDR-C Readouts

The unit contains two set point-operated, single pole relays which may be controlled by either pressure channel in the -2C. Set point adjustment is accomplished by front panel COARSE and FINE controls which cover the entire range of the gauge in use. The relays' status is indicated by front panel lamps. "Failsafe" relay operation is standard, that is, the relays are not energized at pressures higher than the set point settings. The relays can be latched in the energized state by means of an external logic line to the rear panel Interface connector.

The readout is a 4½ place digital panel meter which indicates the output of the attached pressure sensor(s). Engineering units for the readout (mmHg, psi, kPa, mbar, inHg, inH<sub>2</sub>O, cmH<sub>2</sub>O) can be selected by a front panel switch. The meter also reads the current set point values in the same engineering units by means of another front panel switch. The PDR-C-2C has an additional front panel switch which is used to select display of channel 1, display of channel 2, remote channel selection, or automatic channel selection. In automatic channel selection, the PDR-C-2C will display Channel 1 sensor as long as it is less than 100%. If Channel 1 is greater than 100%, Channel 2 will be displayed.

## How This Manual is Organized

This manual is designed to provide instructions on how to set up, install, and operate a Type PDR-C-1C/2C unit.

**Before installing your Type PDR-C-1C/2C unit in a system and/or operating it, carefully read and familiarize yourself with all precautionary notes in the *Safety Messages and Procedures* section at the front of this manual. In addition, observe and obey all WARNING and CAUTION notes provided throughout the manual.**

Chapter One, *General Information*, (this chapter) introduces the product and describes the organization of the manual.

Chapter Two, *Installation*, explains the environmental requirements and describes how to mount the instrument in your system.

Chapter Three, *Overview*, gives a brief description of the instrument and its functionality.

Chapter Four, *Operation*, describes how to use the instrument and explains all the functions and features.

Chapter Five, *Maintenance*, lists any maintenance required to keep the instrument in good working condition.

Chapter Six, *Troubleshooting*, provides a checklist for reference should the instrument malfunction.

Appendix A, *Product Specifications*, lists the specifications of the instrument.

Appendix B, *Model Code Explanation*, describes the model code.

## Customer Support

Standard maintenance and repair services are available at all of our regional MKS Calibration and Service Centers, listed on the back cover. In addition, MKS accepts the instruments of other manufacturers for recalibration using the Primary and Transfer Standard calibration equipment located at all of our regional service centers. Should any difficulties arise in the use of your Type PDR-C-1C/2C instrument, or to obtain information about companion products MKS offers, contact any authorized MKS Calibration and Service Center. If it is necessary to return the instrument to MKS, please obtain an ERA Number (Equipment Return Authorization Number) from the MKS Calibration and Service Center before shipping. The ERA Number expedites handling and ensures proper servicing of your instrument.

Please refer to the inside of the back cover of this manual for a list of MKS Calibration and Service Centers.

---

### Warning



**All returns to MKS Instruments must be free of harmful, corrosive, radioactive, or toxic materials.**

---

## Chapter Two: Installation

### How To Unpack the Type PDR-C-1C/2C Unit

MKS has carefully packed the Type PDR-C-1C/2C unit so that it will reach you in perfect operating order. Upon receiving the unit, however, you should check for defects, cracks, broken connectors, etc., to be certain that damage has not occurred during shipment.

---

**Note**

Do *not* discard any packing materials until you have completed your inspection and are sure the unit arrived safely.

---

If you find any damage, notify your carrier and MKS immediately. If it is necessary to return the unit to MKS, obtain an ERA Number (Equipment Return Authorization Number) from the MKS Service Center before shipping. Please refer to the inside of the back cover of this manual for a list of MKS Calibration and Service Centers.

---

**Caution**

**Only qualified individuals should perform the installation and any user adjustments. They must comply with all the necessary ESD and handling precautions while installing and adjusting the instrument. Proper handling is essential when working with all highly sensitive precision electronic instruments.**

---

### Unpacking Checklist

#### *Standard Equipment:*

- Type PDR-C-1C/2C Unit
- Type PDR-C-1C/2C Instruction Manual (this book)

#### *Optional Equipment:*

- Electrical Connector Accessories Kit - PDR-C-1C-K1 or PDR-C-2C-K1
- Interface cables

## Product Location and Requirements

### Operating Environmental Requirements

- Ambient Operating Temperature: 0° C to 50° C
- Ventilation requirements include sufficient air circulation

### Dimensions

**Note**



All dimensions are listed in inches with millimeters referenced in parentheses.

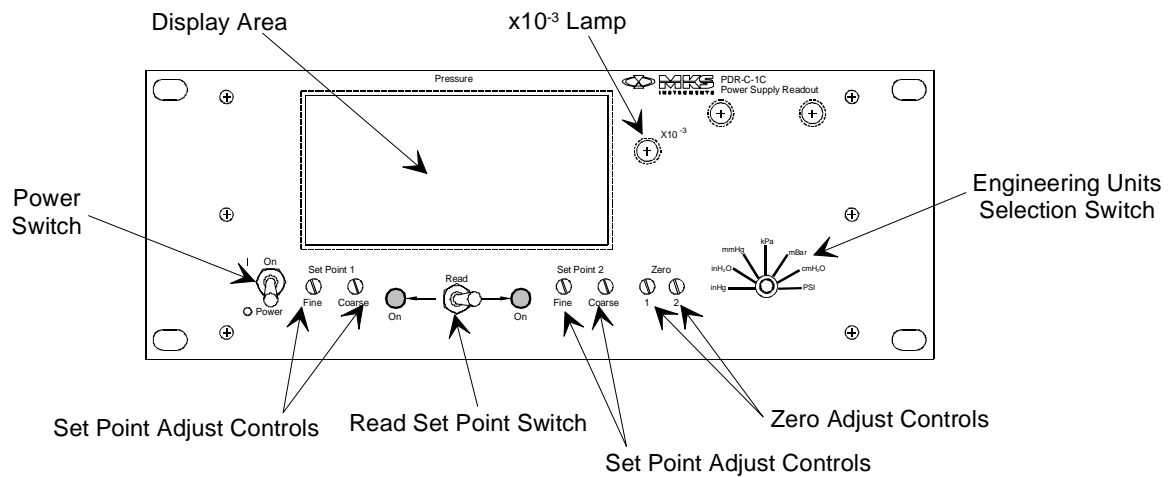

Figure 1: Front Panel of the Type PDR-C-1C Unit

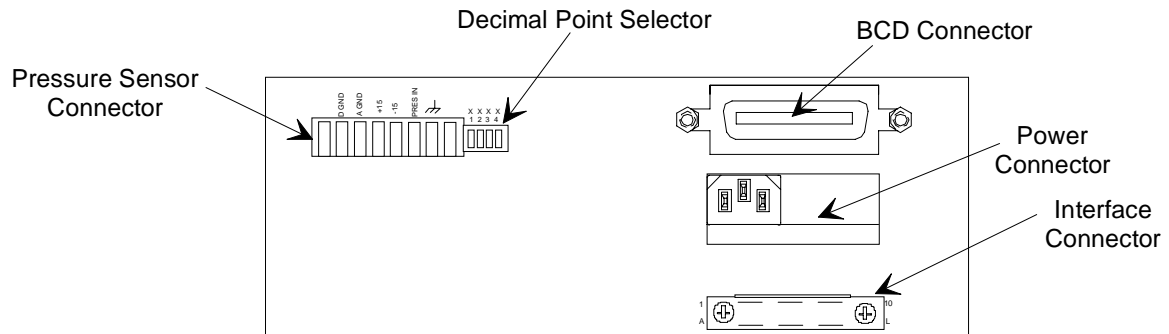
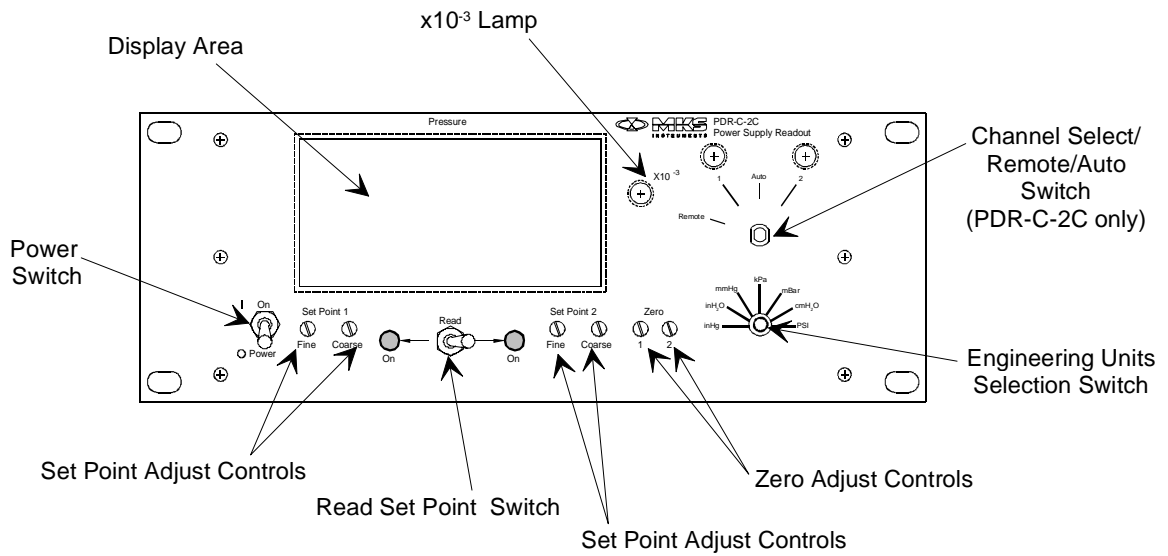

Figure 2: Rear Panel of the Type PDR-C-1C Unit



### PDR-C-2C

Figure 3: Front Panel of the Type PDR-C-2C Unit

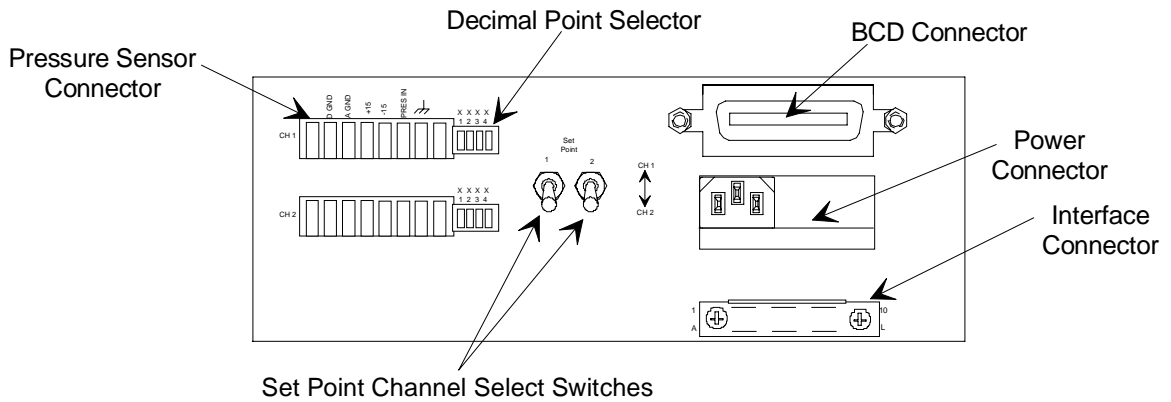

Figure 4: Rear Panel of the Type PDR-C-2C Unit

## Setup

For information regarding the installation of the pressure gauge, refer to the manual for that specific instrument.

### Caution



**Mount the PDR-C-1C/2C in a location that provides adequate air circulation around the unit.**

In some cases the sensor cable attaches to the sensor with bare wires to a terminal block and in other cases the cable attaches to the sensor by a connector. MKS' standard color code for sensor cables follows:

Sensor Cable Identification	
Signal	Color
+15 VDC Power Input	Green
-15 VDC Power Input	White
Pressure Input	Red
Power Ground (Return)	Black
Signal Ground (Return)	Black
Chassis (Case)	Black (large)

Table 6: Sensor Cable Identification

### Grounds

The PDR-C-1C/2C has a three ground system which allows for the separation of the power supply return (D GND) and the DC output signal return (A GND) and the chassis ground. When used with pressure gauges that have only a two ground system, connect the D GND and A GND to that gauge's common ground and then connect the chassis ground of the PDR to the chassis ground of the gauge.

## Chapter Three: Overview

### Rear Panel Connections and Controls

#### Pressure Sensor Connector

These connectors are used to interface the PDR with the pressure gauge(s). They provide power to gauges requiring it, and receive the pressure signal back from the gauge. Refer to Table 9, page 28, for the connections.

#### Decimal Point Selector

These are 4PST rocker switches used to set the display decimal point to the appropriate position for the pressure range being measured. The following chart shows switch settings for various full scale pressure values.

Decimal Point Selector Switch				
Gauge F.S.	Switch Selection			
	1	2	3	4
1 MM	ON	OFF	OFF	OFF
10 MM	OFF	ON	OFF	OFF
100 MM	OFF	OFF	ON	OFF
1000 MM	OFF	OFF	OFF	ON
10000 MM	OFF	OFF	OFF	OFF

Table 7: Decimal Point Selector Switch

#### Note



Closing more than one switch (per channel) will produce multiple decimal points and cause interaction between channels.

## Power Interface Connector

This module accepts a standard power cord, and contains a line fuse, filter, and input voltage selector. The selected line voltage is visible on a small PC board mounted behind the plastic window. To change this voltage proceed as follows:

1. Remove the line cord and slide the plastic window to the left.
2. Pull the fuse lever outward to eject the fuse.
3. Insert a small probe in the hole in the PC card and remove the card.
4. Position the PC board so that the voltage desired is readable from the rear.
5. Plug the card back into the module.
6. Insert the proper value fuse (1 ASB @ 120 VAC or ½ ASB @ 240 VAC).
7. Slide the window to the right.
8. Plug in the line cord.

## Interface Connector (J118)

This 20 pin connector is used for external access to the PDR. Refer to *Interface Connector (J118)*, page 27, for the pinout of the connector. Set point relay connections (NC, NO, COMMON) are available on the connector as well as 0 to 10 Volt full scale analog outputs which are equal to the incoming pressure signal including zero correction. Also available on this connector are the LATCH control lines used to remotely hold the set point relays in the energized state, and a 0 to 1 Volt analog output voltage line whose voltage is equal to the front panel display DVM input voltage. Analog and digital grounds are also brought out. The PDR-C-2C uses three additional lines; two for identification of which channel is currently being displayed and one line for remote selection of which channel is to be displayed.

## BCD Output Connector

### *Optional Feature*

This connector provides 5 Volt BCD logic lines directly from the front panel DVM. It is used for remote pressure reading and it outputs the same quantity as shown on the DVM. The BCD lines are updated approximately every 0.5 seconds, as is the display.

## Set point Channel Select Switches

### *PDR-C-2C only*

These switches are used to select which pressure signal is applied to each of the two set point comparators.



## **Front Panel Controls and Indicators**

### **Power Switch**

In the “On” position, the power switch applies power to the PDR unit.

### **Display (DVM)**

The 4½ place voltmeter accepts 1.9999 Volts full scale. This meter contains its own power supply, and provides display information in BCD form to the rear panel. Decimal point information for the display is obtained from rear panel range rocker switches and internal decoding circuits used in conjunction with the engineering units switch.

### **Zero Adjust Control**

These controls are used as fine zero adjustments for the pressure gauge. An absolute pressure gauge must be pumped down below its resolution before this adjustment can be made; differential gauges should be cross-ported. The zero control on the pressure sensor is used as a coarse zero.

### **Set Point Adjust Controls**

These controls are used to adjust the desired set point level. Range is from 0 to 100% of the full scale pressure.

### **Read Set Point Switch**

This switch connects the pressure signal to the engineering units circuit and ultimately to the display when it is in the center position. When it is switched toward one side or the other it connects the appropriate set point level through the engineering units circuit to the DVM. Thus the set point level is displayed in the same pressure units as the gauge being used. The switch is spring loaded to return to the center position when released.

### **Set Point Relay Indicator Lamps**

These LED's are illuminated when the set point relay is energized. This will occur when the pressure signal is below the set point value.

### **Engineering Units Selection Switch**

This rotary switch is used for selecting which engineering units should be used with the front panel display. Changing this switch will automatically scale the display to the right value and move the decimal point to the appropriate location in the display.

### **x10<sup>-3</sup> Lamp**

This LED indicates when the display is showing units requiring multiplication by 1/1000.

### **Channel Select/Remote/Auto Switch**

*PDR-C-2C only*

If this switch is set in either the “1” or “2” position, the chosen channel’s pressure value will be displayed (unless the READ switch is used).

If this switch is set to the “AUTO” position, then the display will monitor channel 2 at high pressures (it is assumed that channel 2 is connected to a sensor having higher range) until the pressure reading of channel 1’s sensor falls to 90% of its full scale value. The display will continue to monitor channel 1 until channel 1’s pressure reaches 100% of full scale of its pressure gauge, at which time it will automatically switch to monitoring channel 2.

If set for the “REMOTE” position, then an external 5 Volt logic line may be used to select either channel 1 or 2 to be displayed. If a high signal is sent to this line, or if left unconnected, channel 1 will be selected. A low signal voltage will select channel 2.

## Interface Connector (J118) Pinout

Table 8 lists the pinout of the Interface connector, located on the rear panel of the PDR-C-1C/2C unit. Refer to *Interface Connector (J118)*, page 24, for more information.

<b>Interface Connector Pinout</b>	
<b>Pin Number</b>	<b>Assignment</b>
1	Signal Ground
2	Digital Ground
3	No Connection
4	Switched DC Output (in engineering units)
5	No Connection
6	$\overline{\text{Latch 2 Set Point Relay}}$
7	$\overline{\text{Latch 1 Set Point Relay}}$
8	Set Point 1 Relay NO Contact
9	Set Point 1 Relay NC Contact
10	Set Point 1 Relay Common Contact
A	Channel 2 Range ID*
B	Channel 1 Range ID*
C	Remote Channel Select
D	No Connection
E	No Connection
F	Ch 2 DC Output (0 to 10 V, zero corrected)
H	Ch 1 DC Output (0 to 10 V, zero corrected)
J	Set Point 2 Relay NC Contact
K	Set Point 2 Relay NO Contact
L	Set Point 2 Relay Common Contact
* <i>Transistor open collector will sink 10 mA @0.4 V. Maximum off voltage (VCEO) is 25 V.</i>	

Table 8: Interface Connector Pinout

## **Pressure Sensor Terminal Block Connections**

The pressure sensor connector is a 6 position terminal block, located on the rear panel.

<b>Pressure Sensor Terminal Block Connections</b>	
<b>Position</b>	<b>Assignment</b>
1	Digital Ground
2	Analog Ground
3	+15 V
4	-15 V
5	Pressure
6	Chassis Ground

Table 9: Pressure Sensor Terminal Block Connections

## Chapter Four: Theory of Operation

### Pressure Signal

The pressure signal is received from the pressure gauge at the rear panel terminal block and is applied to the input amplifier (U1) where the fine zero correction is added. The output from this amplifier then goes to the output buffer amplifiers (U2, U3) and to the rear panel Interface connector. The output from the input amplifier also goes to the set point switching circuits (through the rear panel Channel Select switches on the PDR-C-2C) and to the Engineering Units scaling circuit (through the DVM selection relay on the PDR-C-2C) which leads ultimately to the display DVM.

### Set Points

Two independent set point relays and their respective switching circuits are included in both the PDR-C-1C and -2C. In the -2C these set points can be selected to monitor either incoming pressure signal by means of rear panel channel selection switches.

The set point circuit compares the incoming pressure signal with an adjustable reference voltage which is set using the front panel Coarse and Fine adjustment controls. The relay logic is such that a no-power condition produces the same relay states that a high-pressure situation will produce. Either set point value may be read on the display DVM in engineering units by toggling the front panel READ switch toward the appropriate side. Asserting either LATCH line on rear panel connector J118 will hold the set point relays de-energized once that state has been reached.

### Overrange Comparator

This circuit monitors the input to the engineering units circuit and causes the display to blank when a pressure signal of approximately 11 or more Volts occurs.

### Power Supply

The power supply provides  $\pm 15$  Volts for internal circuits as well as for the attached pressure gauge. The + and - supplies are identical and are internally protected against shorts and overheating. This supply also generates the precision reference voltage used by the comparators. The display DVM provides its own +5 Volt source which is also used as the supply for 5 Volt logic on the main PC board.

## **Pressure Level Comparators**

*PDR-C-2C only*

The channel 1 pressure signal is applied to two comparators.

One of these is set to trip at 90% of full scale pressure while the other is set for 100%. The comparator outputs are connected to logic whose output goes to the front panel Channel Selector/Function Switch.

## **Channel Selector / Function Switch**

*PDR-C-2C only*

This switch is used to determine which channel's output is displayed by the front panel DVM by choosing which logic level or input is applied to the channel select relay (K1). If the AUTO switch position is chosen then the logic output from the pressure level comparators is applied to the relay switching transistor. Front panel LEDs are used to indicate which channel is being displayed. When the Channel Selector/Function Switch is set to the REMOTE position the user can remotely select which channel is being displayed by inserting the appropriate logic level on pin C of the rear panel Interface connector.

## Chapter Five: Maintenance

### **General Information**

Periodically check for wear on the cables and inspect the enclosure for visible signs of damage.

Should any difficulties be encountered in the use of your instrument, refer to *Customer Support*, page 18, for instructions on how to return the product to MKS.

Should it become necessary to attempt repair in the field, the first step is to isolate the source of the problem to the pressure gauge or the PDR. Any repair made to the pressure gauge will usually require a recalibration. The PDR-C-1C/2C may be repaired without recalibration as long as none of the calibration adjustments have been tampered with.

### **Fault Isolation**

The first step in troubleshooting is to isolate the problem to one of the sections of the PDR. Once this is done the problem can usually be easily located and corrected. The PDR-C-1C/2C can be broken down into the following sections:

- Power Supply
- Pressure Signal Amplification and Readout
- Set Point Circuits
- Channel Selection Circuits (PDR-C-2C only)

Since a problem in the power supply will effect the performance of all sections, it is important to begin fault isolation at this point.

## Power Supply

1. Measure the  $\pm 15$  Volt supplies on the rear panel pressure gauge connector with respect to P GND.

The voltages should be within the range of 14.8 to 15.2 Volts and the AC ripple should be less than 10 mV peak-to-peak. If the voltages appear to be normal, then proceed to check the next section. If supply voltages are incorrect, continue with the step 2.

2. Disconnect the pressure gauge and retest the supply voltages.

If the supplies now appear to be normal, the fault is with the pressure sensor. If the supplies are not normal after removing the pressure sensor, continue with step 3.

3. Remove the power supply jumpers (E1-E2 and E3-E4) in order to isolate the power supply from the rest of the PDR circuits.

If the supplies now are normal, the fault is probably a short circuit in the PDR circuits. If the supplies continue to appear abnormal, contact MKS for assistance.

## Pressure Signal Amplification and Readout

1. Set up the PDR so that it is displaying the output in mmHg from a connected pressure gauge.
2. At the rear panel terminal block, connect an external voltmeter between Signal GND and the Pressure Input.

If this voltage *closely tracks*<sup>1</sup> ( $\pm 0.2$  V) the voltage that is displayed on the front panel DVM but is not representing the correct pressure, the pressure gauge is in error and the PDR unit is operating normally.

If the voltage *does not track*, continue to troubleshoot the PDR unit.

To troubleshoot the signal path of the PDR-C-1C/2C, disconnect the pressure gauge and replace it with two resistors connected in the following manner:

---

**Note**

---

If you have a PDR-C-2C, connect the resistors to Channel 1 and place channel selector to Channel 1.

---

---

<sup>1</sup> A voltage of above approximately 10.8 Volts will cause the digital panel meter to overrange and blank. This is to be considered normal.



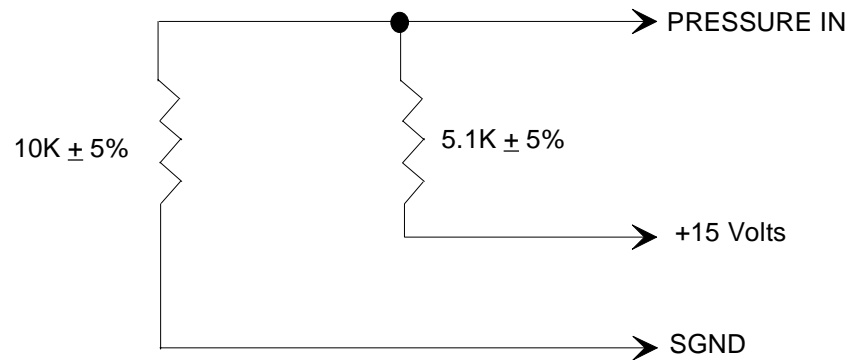

Figure 5: Inserting Two Resistors to Replace the Pressure Sensor Signal

This will produce an input voltage of +9.6 to +10.3 Volts. To produce a zero input, simply short out the 10K $\Omega$  resistor. Set the front panel engineering units switch to the “mmHg” position. Use an external meter to measure the output voltage for this channel (not the “DC OUTPUT”). Reference the meter to SGND on the input connector. The output voltage should track the input voltage developed by the above network to within  $\pm 0.2$  Volts. If not then the problem lies in the channel amplifier and zero circuit. Refer to the circuits involving U1, U2 and U3 in order to troubleshoot to the appropriate component. If the voltage does track but the front panel DVM does not agree, the problem is with either the engineering units resistive divider (R43-R54), relay K1 (PDR-C-2C only), the front panel READ or engineering units switch, or buffer U8. Note that the DVM is 1.9999 Volts full scale and will read out  $\frac{1}{10}$  of the incoming signal voltage when set to the “mmHg” position (ignoring decimal point).

***How To Calibrate the Engineering Units Circuit******Equipment Required:***

1 DVM, 5½ place

1 Precision Variable Voltage Source, 10 Volts

Miscellaneous Bus Wire

Schematic

PC Layout

1. Turn off power to the PDR-C unit.
2. Short the Pressure Input to the Signal GND terminal on the rear panel terminal block (CH 1).
3. Attach the DVM between Analog GND and the zeroed CH 1 signal, available at front panel switch S3 or at one end of R43.
4. Apply power to the PDR unit.
5. Adjust the front panel ZERO trimmer for a  $0.000 \pm 0.0005$  Volt DVM reading.
6. Shut off power to the PDR.
7. Attach the voltage source between the Pressure Input and Signal GND terminals.
8. Apply power and a voltage source of  $10.0000 \pm 0.0005$  Volts, as measured by the DVM.
9. Ignore the decimal point on the front panel display and use Table 10 to set the appropriate trimmer for a correct display of the chosen engineering units.

<b>Correct Trimmer for Selected Engineering Units</b>		
<b>Engineering Units</b>	<b>Trimmer</b>	<b>Front Panel DVM</b>
mbar	R47	13332
kPa	R47	13332
mmHg	R49	10000
psi	R44	19337
cmH <sub>2</sub> O	R55	13597
inH <sub>2</sub> O	R51	5353
in Hg	R53	3937

Table 10: Correct Trimmer for Selected Engineering Units

## Set Point Circuits

With the input section zeroed and 10 Volts input applied as described above in “Calibration of Engineering Units” (place PDR-C-2C rear panel SET POINT switches in “CH 1” position), check voltages at U20 pin 5 and U16 pin 3 to be 10.000 Volts. If not, check continuity from R5 and R6 through jumpers E7-E8 and E9-E10 (PDR-C-1C) or through rear panel switches S7 and S8 (PDR-C-2C).

If 10 Volts is read at U20 and U16 then check the voltage at U20 pin 3 and verify it with the front panel DVM, with engineering units set to “mmHg” position. Do this by moving the front panel SET POINT switch to the left for CH 1. Similarly check U16 pin 5 to be the same as the front panel display with the SET POINT switch to the right (CH2). Varying the COARSE and FINE set point trimmers should vary the display voltages accordingly.

By changing the incoming “pressure” signal from the voltage source to be close to the set point voltage, the outputs of both set point comparators (U18A pin 1 and U18B pin 7) should switch between the positive and negative supply rails. This in turn should cause U17 pins 10 and 4 to vary inversely between 0 Volts and the positive supply (be sure the LATCH lines are in a high state-U17 pin 12 and pin 1). Next check the outputs from U19 pins 1 and 7 to ensure switching between rails. If the above all works, any problem must be with the relay drivers Q5 and Q6 or relays K2 and K3 and associated components.

## Channel Selection Circuits

### *PDR-C-2C only*

If no channel selection is indicated, check J113 pin 2 to be connected to digital ground and J113 pin 1 to be +5 Volts. If digital ground is at fault, check continuity back to the power supply. If +5 Volts is at fault, check wiring from the front panel DVM (+5 Volt supply comes from the DVM!). If both are fine and no channel switching occurs, check the collector voltages of Q1 and Q2 to verify that one is at 0 Volts and the other is at +15 Volts. If this is correct check that relay K1 is switching when changing channel selection from CH 1 to CH 2 and back. If remote channel selection malfunctions, check U6 pin 4 to be switching inversely to an applied +5 Volt logic signal on rear panel Interface connector (J118) pin C.

If problems exist with the AUTO channel selection circuit, first select AUTO operation and attach the voltage source to channel 1 Pressure Input as previously described. While monitoring the voltage at U4 pin 1, vary the incoming voltage from approximately 8 Volts up to 11 Volts noting that U4 pin 1 should switch high at approximately 10 Volts input. If not, check circuit or adjust R16. Next do the same test while monitoring U4 pin 7, noting that switching should occur with approximately 9 Volts input. If this all checks out, next measure U5 pin 4 to be switching high at approximately 10 Volts as the input increases from 8 Volts. Next decrease from 11 Volts and note U5 pin 4 to be switching low as the input voltage equals approximately 9 Volts. If this is happening and automatic channel selection is not occurring, the relay (K1) driver circuits are at fault.

This page intentionally left blank.

## Appendix A: Product Specifications

### Physical Specifications

Connectors	
Interface	20-pin
Pressure Sensor	6 position terminal block
Dimensions	Standard ½ rack size
Display	4½ place, 7 segment planar LED, red
Weight	3.2 kg

### Environmental Specifications

Maximum Operating Temperature	50° C
-------------------------------	-------

### Electrical Specifications

Power Consumption	65 Watts, full load
Operating Voltage	117/234 ±15%, 50-60 Hz
Power Supply Outputs	±15 Volts @ 600 mA, max ripple < 10 mV
Analog DC Outputs	0 to 10 VDC into 10K ohms or greater 0 to 1.999 VDC scaled output into 10K ohms or greater
Meter Accuracy	0.01% of reading ±1 digit
Input Impedance	900K ohms
Zero Adjustment Range	±1.5% of full scale

## **Set Point Specifications**

Set Point Relay Configuration	2 separate circuits, on the PDR-C-2C they can be connected to either pressure channel with rear mounted toggle switches.
Contact Configuration	Single Pole Form C (SPDT) brought out to the rear panel. One for each set point.
Contact Rating	2A @ 28 VDC, 1A @ 120 VAC resistive.
Set Point Hysteresis	0.5% of full scale
Set Point Adjustment Range	100% of full scale (coarse and fine)
Relay Control	Digital Low on relay latch line holds the relay off once it has been de-energized.
BCD Outputs (optional)	Output parallel line BCD (1 TTL load each TTL and CMOS compatible).

Due to continuing research and development activities, these product specifications are subject to change without notice.

## Appendix B: Model Code Explanation

### Model Code

The options of your transducer are identified in the model code when you order the unit.

The model code is identified as follows:

**PDRCXXYYY**

where:

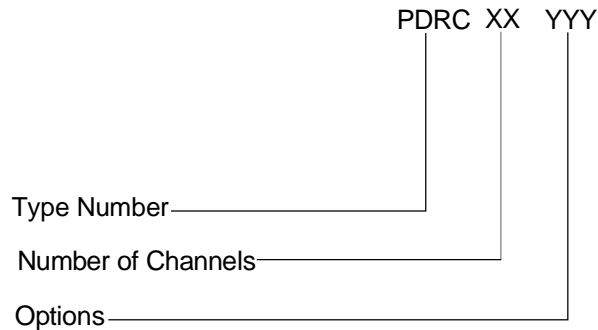

#### **Type Number (PDRC)**

This designates the model number of the instrument.

#### **Number of Channels (XX)**

The number of channels is indicated by a one digit / one letter code.

	<b>Ordering Code</b>
One Channel	1C
Two Channel	2C

#### **Options (YYY)**

The choice of options is designated by up to three letters.

	<b>Ordering Code</b>
BCD Option	BCD
CE Mark Compliance	E

This page intentionally left blank.



## Appendix C: BCD Option

### General Information

This option provides a latched and buffered BCD output at the rear panel. The panel meter's BCD information is enabled or disabled by six control lines. When these lines are tied together and connected to digital ground all of the BCD information is present at the rear connector and can be read when the DATA READY goes high. When these lines are open all of the panel meter's BCD lines are open. This is done so that several meters can be connected to a common bus and strobed for a reading by grounding the appropriate control lines. The BCD outputs can be interfaced to a computer or digital printer. The pinout of the rear panel connector is shown in Table 11.

#### Note



Decimal information from the main board is *not* tri-stated and should not be connected to a common bus.

BCD Connector Pinout			
BCD Data	Pin Number	BCD Data	Pin Number
1	8	10000	5
2 DIGIT 1	36	$\overline{\text{POLARITY}(+)}$	27
4	38	$\overline{\text{OVERRANGE}}$	26
8	40	$\overline{\text{ENABLE DIGIT 5}}$	31
$\overline{\text{ENABLE DIGIT 1}}$	17	$\overline{\text{ENABLE REMAINDER}}$	34
10	16		3
20 DIGIT 2	14	DIGIT COMMON	28
40	12	DIGIT COMMON	4
80	35	DIGIT COMMON	3
$\overline{\text{ENABLE DIGIT 2}}$	7	DATA READY	30

Table 11: BCD Connector Pinout  
(Continued on next page)

<b>BCD Connector Pinout (Continued)</b>			
<b>BCD Data</b>	<b>Pin Number</b>	<b>BCD Data</b>	<b>Pin Number</b>
100	10	$\overline{+3P}$	22
200 DIGIT 3	11	$\overline{+2P}$	23
400	13	$\overline{+1P}$	44
800	42	$\overline{0P}$	45
$\overline{\text{ENABLE DIGIT 3}}$	41	$\overline{-1P}$	47
		$\overline{-2P}$	48
1000	15		
2000 DIGIT 4	39		
4000			
8000	33		
$\overline{\text{ENABLE DIGIT 4}}$	32		

Table 11: BCD Connector Pinout

## Index

### B

BCD, 24, 25, 39, 41–42

### C

Cables, 22

CE compliance, 39

Channels

two, 26, 35

Channels, number, 39

Chassis ground, 22

Connector

Interface, 24, 27, 29

Power, 24

Pressure Sensor, 23, 28

Customer support, 18

### D

Decimal point, 23

Display, 17, 23, 25, 37

### E

Engineering units, 17, 25

### F

Failsafe, 17

Fault isolation, 31

Fuses, 24

### G

Ground, 22

### I

Interface cables, 22

Interface connector, 24, 27, 29

### M

Manual organization, 18

Model code, 39

### O

Options, 39

Overrange, 29

### P

Power connector, 24

Power consumption, 37

Power supply, 17, 29, 32

Pressure Sensor connector, 23, 28

Pressure units, 17, 25

### R

Relay, 17, 24, 27, 29, 38

Remote, 26, 30

Returning the product, 18, 19

### S

Set point, 17, 24, 25, 27, 29, 35, 38

### T

Temperature, 20

**U**

Units, 17, 25

**V**

Ventilation, 20, 22

**Z**

Zero, 25